

## The future will be IT driven, we make you part of it

Our IPC Machine Controller combines proven machine automation with the freedom to use PC technology: working together but independently. So you can leverage Big Data, NUI and IoT to explore manufacturing innovation with no compromise on traditional PLC reliability and robustness. It makes engineers unstoppable and machines innovative yet reliable.



NY512



NY532

## Features

- OS independency allows controller to continue to control if a Windows OS crashes
- Primary task period 500  $\mu$ s/24 axes
- Retain/non-retain variables 4 MB/64 MB
- 16 to 64 axes
- 192 EtherCAT slaves
- Secure boot and recovery methods
- Powerful 7th-generation CPU technology for optimum performance
- No internal cables in the PC part eliminates faults, maximizes uptime
- Unique simplified thermal design to cut downtime
- Two Gbps Ethernet, one EtherCAT, one DVI, one UPS I/O connector
- Two USB2.0 and two USB3.0 for fast data-transmission

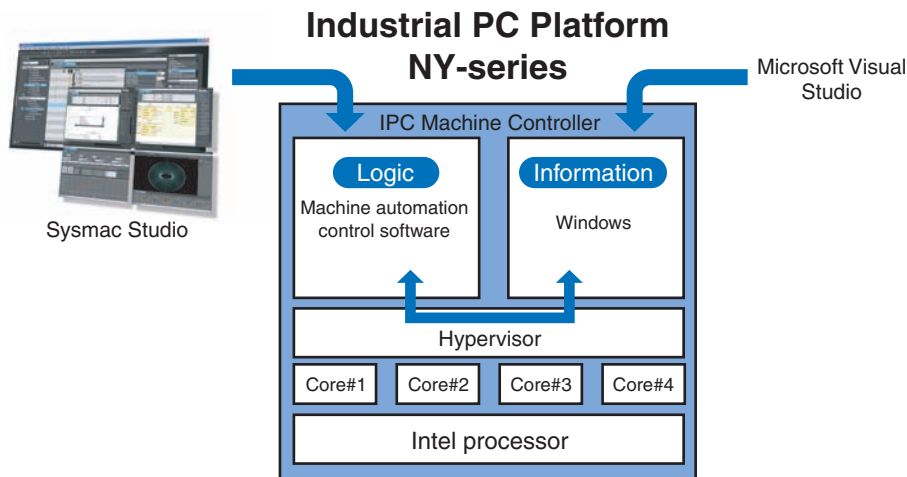

Sysmac is a trademark or registered trademark of OMRON Corporation in Japan and other countries for OMRON factory automation products. Microsoft, Visual Studio and Windows are either registered trademarks or trademarks of Microsoft Corporation in the United States and/or other countries. EtherCAT® is a registered trademark of Beckhoff Automation GmbH for their patented technology. EtherNet/IP™, DeviceNet™ are trademarks of the ODVA. The SD and SDHC logos are trademarks of SD-3C, LLC. Intel, Celeron and Intel Core are trademarks or registered trademarks of Intel Corporation or its subsidiaries in the United States and other countries. Other company names and product names in this document are the trademarks or registered trademarks of their respective companies. The product photographs and figures that are used in this document may vary somewhat from the actual products.

# System Configuration

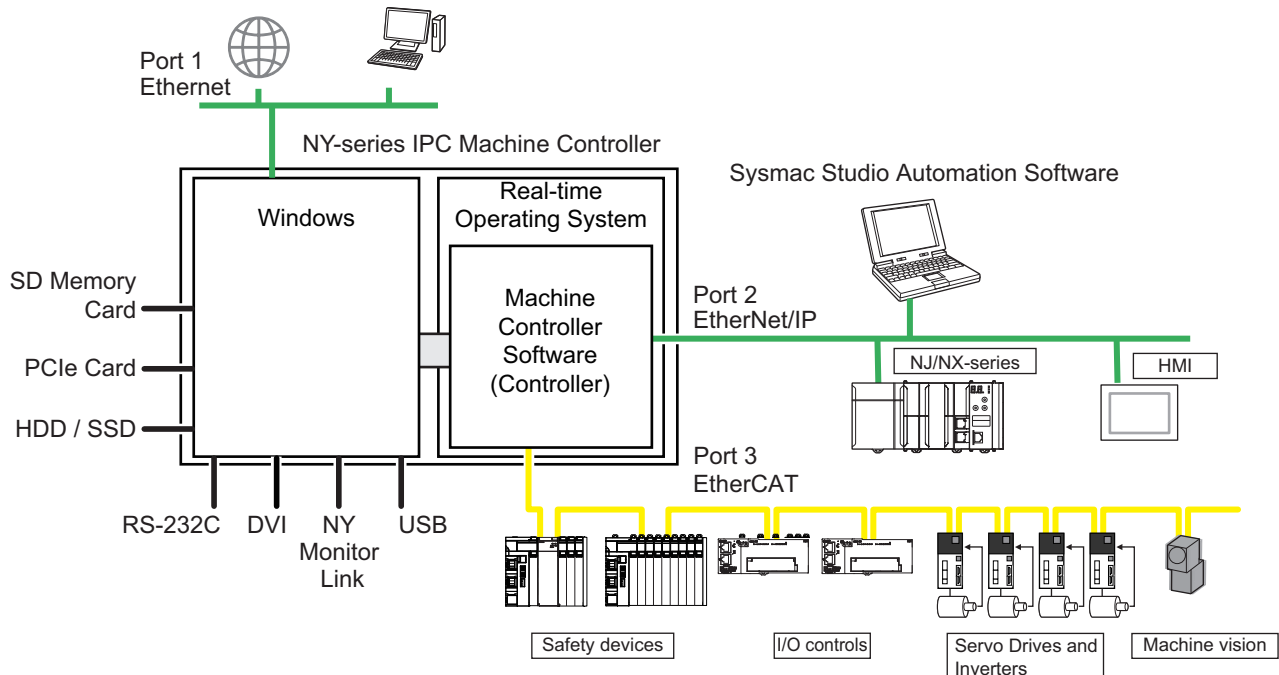

# Model Number Structure

The purpose of this model number structure is to provide understanding of the meaning of specifications from the model number. Models are not available for all combinations of code numbers.

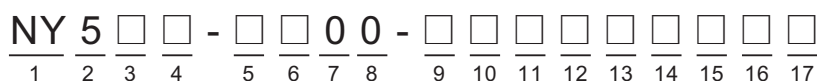

Item		Description	Option	Standard model
1	Series name	NY	NY-series Industrial PC Platform	Yes
2	Controller specifications	5	Large scale, high speed and high precision control application for up to 64 axes.	Yes
3	Model type	1	Industrial Box PC	Yes
		3	Industrial Panel PC	Yes
4	Sequential number	2 or more		Yes
5	Function module	1	Standard	Yes
		3	16 axes	Yes
6	Number of axes for motion control	4	32 axes	Yes
		5	64 axes	Yes
		0	---	Yes
7	Additional function software module	0	---	Yes
8	Reserved	0	---	Yes
9	Expansion slots	0	No PCIe slot	Yes
		1	1 PCIe slots	Yes
10	Frame type	1	Aluminum frame, black, and projected capacitive touch type	Yes
		2	Aluminum frame, Nickel plating, and projected capacitive touch type	Yes
		X	No display (Industrial Box PC)	Yes
11	Display size	1	12.1 inch model	Yes
		2	15.4 inch model	Yes
		3	18.5 inch model	Yes
		X	No display (Industrial Box PC)	Yes
12	OS	2	Windows Embedded Standard 7 - 64 bit	No *2
		4	Windows 10 IoT Enterprise 2019 LTSC - 64 bit	Yes
13	Processor	1	Intel® Core™ i7-4700EQ 4th generation CPU with Fan Unit for active cooling	No *2
		4	Intel® Core™ i5-7440EQ 7th generation CPU with Fan Unit for active cooling	Yes
14	Main memory	3	8 GB, non-ECC	Yes
		5	32 GB, non-ECC	Yes
15	Storage	6	128 GB, CFast MLC	Yes
		7	256 GB, CFast MLC	Yes
		8	32 GB, SSD SLC	No *2
		9	64 GB, SSD SLC	Yes
		C	320 GB, HDD	No *2
		K	128 GB, SSD MLC	Yes
		P	1 TB, SSD 3DTLC	Yes
16	Optional interface	0	No optional interface	Yes
		1	RS-232C	Yes
		2	DVI-D	Yes
		6	NY Monitor Link	Yes
17	Logo	0	OMRON	Yes
		2	Customized logo *1	Yes
		X	No display (Industrial Box PC)	Yes

\*1. Customization only available in Europe.

\*2. End of Life products: only available for service purpose

## Ordering Information

### Recommended models

The industrial PC Platform has extended configuration possibilities to meet your requirements, below an overview of the most used and recommended models. Selecting one of the models below will bring the benefit of faster delivery times. In case your preferred model is not listed below, please contact your Omron representative to discuss the possibilities.

### NY-series IPC Machine Controller

Product name	Specifications						Model
	Operating system	CPU type	Number of motion axes	RAM memory (non-ECC type)	Storage size	Interface option	
Industrial Box PC	Windows 10 IoT Enterprise 2019 LTSC 64bit	Intel® Core™ i5-7440EQ	64	32 GB	128 GB SSD MLC	RS-232C	NY512-1500-1XX445K1X
				8 GB	256 GB CFast MLC	No	NY512-1500-0XX44370X
			32	32 GB	128 GB SSD MLC	RS-232C	NY512-1400-1XX445K1X
				8 GB	256 GB CFast MLC	No	NY512-1400-0XX44370X
			16	32 GB	128 GB SSD MLC	RS-232C	NY512-1300-1XX445K1X
				8 GB	256 GB CFast MLC	No	NY512-1300-0XX44370X
Industrial Panel PC	Windows 10 IoT Enterprise 2019 LTSC 64bit	Intel® Core™ i5-7440EQ	64	32 GB	256 GB CFast MLC	No	NY532-1500-011443600
				8 GB	128 GB CFast MLC		NY532-1500-011443600
			32	32 GB	256 GB CFast MLC		NY532-1400-011445700
				8 GB	128 GB CFast MLC		NY532-1400-011443600
			16	32 GB	256 GB CFast MLC		NY532-1300-011445700
				8 GB	128 GB CFast MLC		NY532-1300-011443600

### Automation Software Sysmac Studio

The Sysmac Studio is the software that provides an integrated environment for setting, programming, debugging and maintenance of machine automation controllers including the NJ/NX-series CPU Units, NY-series Industrial PC, EtherCAT Slave, and the HMI.

For details, refer to your local OMRON website and *Sysmac Studio Catalog* (Cat. No. P138).

### Collection of software functional components Sysmac Library

Please download it from following URL and install to Sysmac Studio.

[http://www.ia.omron.com/sysmac\\_library/](http://www.ia.omron.com/sysmac_library/)

### Typical Models

Product	Features	Model
Vibration Suppression Library	The Vibration Suppression Library is used to suppress residual vibration caused by the operation of machines.	SYSMAC-XR006
Device Operation Monitor Library	The Device Operation Monitor Library is used to monitor the operation of devices such as air cylinders, sensors, motors, and other devices.	SYSMAC-XR008
Dimension Measurement Library	The Dimension Measurement Library is used to dimension measurement with ZW-7000/5000 Confocal Fiber Displacement Sensor, or E9NC-TA0 Contact-Type Smart Sensor.	SYSMAC-XR014

## Accessories

### Optional Hardware

Product name	Specifications	Model
Mounting Brackets *1	Book mount	NY000-AB00 NY000-AB05
	Wall mount	NY000-AB01
	VESA mount	NY000-AB06
	VESA mount	NY000-AB07
	VESA mount	NY000-AB08
	VESA mount	NY000-AB09
	VESA mount	NY000-AB10
	VESA mount	NY000-AB11
	VESA mount handle	NY000-AB12
SD Memory Cards	Card type: SD Card Capacity: 2 GB Format: FAT16	HMC-SD292
	Card type: SDHC Card Capacity: 4 GB Format: FAT32	HMC-SD492
	Card type: SDHC Card Capacity: 16 GB Format: FAT32	HMC-SD1A2
USB Flash Drives	Capacity: 2 GB	FZ-MEM2G
	Capacity: 8 GB	FZ-MEM8G
Storage Devices	Storage type: HDD Capacity: 320 GB	NY000-AH00 *3
	Storage type: SSD SLC Capacity: 32 GB	NY000-AS00 *3
	Storage type: SSD SLC Capacity: 64 GB	NY000-AS01
	Storage type: SSD SLC Capacity: 64 GB	NY000-AS03
	Storage type: SSD MLC Capacity: 128 GB	NY000-AS04
	Storage type: SSD 3DTLC Capacity: 1 TB	NY000-AS07
	Storage type: CFast MLC Capacity: 128 GB	NY000-AT01
	Storage type: CFast MLC Capacity: 256 GB	NY000-AT02
DVI Cables	Cable length: 2 m Supports DVI-D Minimum bend radius: 36 mm	NY000-AC00 2M
	Cable length: 5 m Supports DVI-D Minimum bend radius: 36 mm	NY000-AC00 5M
Industrial Monitor	<ul style="list-style-type: none"> <li>• LCD touchscreen</li> <li>• Multi-touch functionality</li> <li>• Supply voltage: 24 VDC</li> <li>• Up to 1,280 x 800 pixels at 60 Hz</li> <li>• 2 USB Type-A Connectors</li> <li>• Programmable brightness control</li> <li>• Standard and 100 m cable models are available.</li> </ul>	NYM1□W-C1□□□
Power Supply	<ul style="list-style-type: none"> <li>• Output voltage: 24 VDC</li> <li>• Push-In Plus terminal blocks</li> </ul>	S8VK-G□□□24
	<ul style="list-style-type: none"> <li>• Output voltage: 24 VDC</li> <li>• EtherNet/IP, Modbus TCP-Compatible</li> </ul>	S8VK-X□□□24A-EIP
	<ul style="list-style-type: none"> <li>• Output voltage: 24 VDC</li> <li>• Compact</li> </ul>	S8VK-S□□□24
	<ul style="list-style-type: none"> <li>• Output voltage: 24 VDC</li> <li>• Three-phase 200-V Power Supplies</li> </ul>	S8VK-WA□□□24
UPS *2	Output voltage during backup operation: 24 VDC ± 5%	S8BA

Product name	Specifications	Model
UPS Communication Cable	Cable length: 2 m Signals for <ul style="list-style-type: none"> <li>• Signal output (BL, TR, BU, WB)</li> <li>• Remote ON/OFF input</li> <li>• UPS Stop Signal input (BS)</li> </ul>	S8BW-C02

**Note:** Orders for NY000-AS02 are no longer accepted, as of November 30, 2018.

**\*1.** Select the required type below. Industrial Box PC type only.

NY000-AB00: for NY51□-1□00-1□

NY000-AB05: for NY51□-1□00-0□

Select the required type below. Industrial Panel PC and Industrial Monitor type only.

NY000-AB06: for NYM12W

NY000-AB07: for NYM15W

NY000-AB08: for NYM19W

NY000-AB09: for NY53□-1□00-0□1□4

NY000-AB10: for NY53□-1□00-0□2□4

NY000-AB11: for NY53□-1□00-0□3□4

NY000-AB12 Handle for AB06 to AB11

**\*2.** Revision number 09 or higher.

The revision number of the UPS can be retrieved from the serial number label on the product and the product packaging.

A3□ □□□□□□□□ □□ □  
 1            2            3 4

Item	Description
1	Product code
2	Product period and sequential number
3	Revision number
4	RoHS status

**\*3.** End of Life: only available for support purpose

## Spare Parts

The following spare parts for the Industrial PC are available.

Product name	Specifications	Model
<b>Battery</b>	One battery is supplied with the Industrial PC. The battery supplies power to the real-time clock. The battery is located inside the Industrial PC. Service life: 5 years at 25°C	CJ1W-BAT01
<b>Fan Unit</b>	The Fan Unit is available for the Industrial PC that has active cooling. Service life: 70,000 hours of continuous operation at 40°C with 15% to 65% relative humidity. Shelf life: 6 months This is the storage limitation with no power supplied.	NY000-AF00
<b>Accessory Kit</b>	Replacement kit containing all accessories supplied with Industrial PC. <ul style="list-style-type: none"> <li>• Power connector</li> <li>• I/O connector</li> <li>• Drive bracket for drive installation</li> <li>• 4 mounting screws for drive installation</li> <li>• PCIe Card support for PCIe Card installation</li> <li>• PCIe Card clip for PCIe Card installation</li> </ul>	NY000-AK00
	Power connectors (10 pcs) for Industrial Box PC and Industrial Panel PC	NY000-AK01





## Installed Support Software

Item	Specifications
Industrial PC Support Utility	The Industrial PC Support Utility is a software utility to assist in diagnosing and resolving problems of the Industrial PC. It is pre-installed on the Industrial Box PC and the Industrial Panel PC.
Industrial PC Tray Utility	The Industrial PC Tray Utility is a software utility that provides information about the current state of the Industrial PC, its related devices, and associated software. It is pre-installed on the Industrial Box PC and the Industrial Panel PC.
Industrial PC System API	The Industrial PC System API allows programmers to create programs that can retrieve information or set an indicator status of the Industrial PC. The API makes use of the included IPC System Service to manage the hardware. It is pre-installed on the Industrial Box PC and the Industrial Panel PC.
Industrial Monitor Utility	The Industrial Monitor Utility provides a user interface to control settings and display details of connected Industrial Monitors. It is pre-installed on the Industrial Box PC and the Industrial Panel PC.
Industrial Monitor Brightness Utility	The Industrial Monitor Brightness Utility is a small software utility that allows you to control the brightness of the screen backlight of all connected Industrial Monitors. It is pre-installed on the Industrial Box PC and the Industrial Panel PC.
Industrial Monitor API	The Industrial Monitor API allows programmers to create applications that can control the hardware features and retrieve information from connected Industrial Monitors. It is pre-installed on the Industrial Box PC and the Industrial Panel PC.
Industrial PC Rescue Disk Creator	The Industrial PC Rescue Disk Creator creates a USB Rescue Disk which can be used to back-up and restore the Omron IPC Operating System. It is pre-installed on the Industrial Box PC and the Industrial Panel PC.

### Recommended EtherCAT and EtherNet/IP Communications Cables

Use a straight STP (shielded twisted-pair) cable of category 5 or higher with double shielding (aluminum tape and braiding) for EtherCAT. For EtherNet/IP, required specification for the communications cables varies depending on the baud rate. For 100BASE-TX/10BASE-T, use a straight or cross STP (shielded twisted-pair) cable of category 5 or higher. For 1000BASE-T, use a straight or cross STP cable of category 5e or higher with double shielding (aluminum tape and braiding).

### Cabel with Connectors

Item	Appearance	Recommended manufacturer	Cable length (m)	Model
Cable with Connectors on Both Ends (RJ45/RJ45) Standard RJ45 plugs type *1 Wire Gauge and Number of Pairs: AWG26, 4-pair Cable Cable Sheath material: PUR Cable color: Yellow *2 EtherCAT/ EtherNet/IP (10BASE/100BASE)		OMRON	0.3	XS6W-6PUR8SS30CM-YF
			0.5	XS6W-6PUR8SS50CM-YF
			1	XS6W-6PUR8SS100CM-YF
			2	XS6W-6PUR8SS200CM-YF
			3	XS6W-6PUR8SS300CM-YF
			5	XS6W-6PUR8SS500CM-YF
Cable with Connectors on Both Ends (RJ45/RJ45) Rugged RJ45 plugs type *1 Wire Gauge and Number of Pairs: AWG22, 2-pair Cable Cable color: Right blue EtherCAT/ EtherNet/IP (10BASE/100BASE)		OMRON	0.3	XS5W-T421-AMD-K
			0.5	XS5W-T421-BMD-K
			1	XS5W-T421-CMD-K
			2	XS5W-T421-DMD-K
			5	XS5W-T421-GMD-K
			10	XS5W-T421-JMD-K
Cable with Connectors on Both Ends (M12 Straight/M12 Straight) Shield Strengthening Connector cable *3 M12/Smartclick Connectors Wire Gauge and Number of Pairs: AWG22, 2-pair Cable Cable color: Black EtherCAT/ EtherNet/IP (10BASE/100BASE)		OMRON	0.5	XS5W-T421-BM2-SS
			1	XS5W-T421-CM2-SS
			2	XS5W-T421-DM2-SS
			3	XS5W-T421-EM2-SS
			5	XS5W-T421-GM2-SS
			10	XS5W-T421-JM2-SS
Cable with Connectors on Both Ends (M12 Straight/RJ45) Shield Strengthening Connector cable *3 M12/Smartclick Connectors Rugged RJ45 plugs type Wire Gauge and Number of Pairs: AWG22, 2-pair Cable Cable color: Black EtherCAT/ EtherNet/IP (10BASE/100BASE)		OMRON	0.5	XS5W-T421-BMC-SS
			1	XS5W-T421-CMC-SS
			2	XS5W-T421-DMC-SS
			3	XS5W-T421-EMC-SS
			5	XS5W-T421-GMC-SS
			10	XS5W-T421-JMC-SS

- \*1. Cables with standard RJ45 plugs are available in the following lengths: 0.2 m, 0.3 m, 0.5 m, 1 m, 1.5 m, 2 m, 3 m, 5 m, 7.5 m, 10 m, 15 m, 20 m. Cables with rugged RJ45 plugs are available in the following lengths: 0.3 m, 0.5 m, 1 m, 2 m, 3 m, 5 m, 10 m, 15 m. For details, refer to the *Industrial Ethernet Connectors Catalog* (Cat. No. G019).
- \*2. Cable colors are available in yellow, green, and blue.
- \*3. For details, contact your OMRON representative.

### Cables / Connectors

Item		Recommended manufacturer	Model	
Products for EtherCAT or EtherNet/IP (1000BASE-T *3/ 100BASE-TX)	Wire Gauge and Number of Pairs: AWG24, 4-pair Cable	Cables Kuramo Electric Co.	KETH-SB *1	
		RJ45 Connectors Panduit Corporation	MPS588-C *1	
Products for EtherCAT or EtherNet/IP (100BASE-TX/10BASE-T)	Wire Gauge and Number of Pairs: AWG22, 2-pair Cable	Cables Kuramo Electric Co.	KETH-PSB-OMR *2	
			JMACS Japan Co., Ltd.	PNET/B *2
		RJ45 Assembly Connector 	OMRON	XS6G-T421-1 *2

- \*1. We recommend you to use above Cable, and RJ45 Connector together.
  - \*2. We recommend you to use above Cable, and RJ45 Assembly Connector together.
  - \*3. The products can be used only with thes NX701.
- Note:** Connect both ends of cable shielded wires to the connector hoods.



# Specifications

## Performance Specifications Supported by NY5□□-1

Item			NY5□□-			
			15□□	14□□	13□□	
Processing time	Instruction execution times	LD instruction	0.33 ns			
		Math instructions (for Long Real Data)	1.2 ns or more			
Programming	Program capacity *1	Size	40 MB			
		Number	POU definition	3,000		
			POU instance	24,000		
	Variables capacity	No retain attribute	Size	64 MB		
			Number	180,000		
		Retain attribute	Size	4 MB		
	Number		40,000			
Data type	Number	4,000				
Unit configuration	Maximum number of connectable units	Maximum number of NX unit on the system	4,096 (on NX series EtherCAT slave terminal)			
Motion control	Number of controlled axes	Maximum number of controlled axes	Maximum number of axes which can be defined. The number of controlled axes = The number of motion control axes + The number of single-axis position control axes.			
			64 axes	32 axes	16 axes	
		Motion control axes	Maximum number of motion control axes which can be defined. All motion control function is available.			
			64 axes	32 axes	16 axes	
		Maximum number of used real axes	Maximum number of used real axes. The Number of used real axes includes following servo axes and encoder axes.			
			Used motion control servo axes	Maximum number of servo axes which all motion control function is available. The number of used motion control servo axes = The number of motion control axes whose axis type is set to servo axis and axis use is set to used axis.		
	64 axes	32 axes		16 axes		
	Maximum number of axes for linear interpolation axis control	4 axes per axes group				
	Number of axes for circular interpolation axis control	2 axes per axes group				
	Maximum number of axes groups	32 axes groups				
	Motion control period	The same control period as that is used for the process data communications cycle for EtherCAT.				
	Cams	Number of cam data points	Maximum points per cam table	65,535 points		
			Maximum points for all cam tables	1,048,560 points		
	Maximum number of cam tables	640 tables				
Position units	Pulses, millimeters, micrometers, nanometers, degrees and inches					
Override factors	0.00% or 0.01% to 500.00%					

\*1. This is the capacity for the execution objects and variable tables (including variable names).

Item		NY5□□-				
		15□□	14□□	13□□		
Built-in EtherNet/IP Port	Number of port		1			
	Physical layer		10BASE-T/100BASE-TX/1000BASE-T			
	Frame length		1,514 max.			
	Media access method		CSMA/CD			
	Modulation		Baseband			
	Topology		Star			
	Baud rate		1Gbps (1000BASE-T)			
	Transmission media		STP (shielded, twisted-pair) cable of Ethernet category 5, 5e or higher			
	Maximum transmission distance between Ethernet switch and node		100 m			
	Maximum number of cascade connections		There are no restrictions if Ethernet switch is used.			
	CIP service: Tag data links (Cyclic communications)	Maximum number of connections		128		
		Packet interval *2		1 to 10,000 ms in 1.0-ms increments Can be set for each connection.		
		Permissible communications band *3		20,000 pps including heartbeat		
		Maximum number of tag sets		128		
		Tag types		Network variables		
		Number of tags per connection (i.e., per tag set)		8 (7 tags if Controller status is included in the tag set.)		
		Maximum link data size per node (total size for all tags)		184,832 byte		
		Maximum number of tag		256		
		Maximum data size per connection		1,444 bytes		
		Maximum number of registrable tag sets		128 (1 connection = 1 tag set)		
	Cip Message Service: explicit messages	Class 3 (number of connections)		64 (clients plus server)		
UCMM (non-connection type)		Maximum number of clients that can communicate at one time		32		
		Maximum number of servers that can communicate at one time		32		
Maximum number of TCP socket service		30				
Built-in EtherCAT port	Number of port		1			
	Communications standard		IEC 61158 Type12			
	EtherCAT master specifications		Class B (Feature Pack Motion Control compliant)			
	Physical layer		100BASE-TX			
	Modulation		Baseband			
	Baud rate		100 Mbps (100Base-TX)			
	Duplex mode		Auto			
	Topology		Line, daisy chain, and branching			
	Transmission media		Twisted-pair cable of category 5 or higher (double-shielded straight cable with aluminum tape and braiding)			
	Maximum transmission distance between nodes		100 m			
	Maximum number of slaves		192			
	Range of node address		1-512			
	Maximum process data size		Inputs: 5,736 bytes Outputs: 5,736 bytes (However, the maximum number of process data frames is 4.)			
	Maximum process data size per slave		Inputs: 1,434 bytes Outputs: 1,434 bytes			
	Communications cycle		500 μs to 8 ms (in 250-μs increments)			
Sync jitter		1 μs max.				
Unit configuration	Maximum number of connectable Units	Maximum number of NX Units for entire controller		4,096 (On EtherCAT Slave Terminals)		
	Maximum number of Expansion Racks		0			
Internal clock		At ambient temperature of 55°C: -3.5 to +0.5 min error per month At ambient temperature of 25°C: -1.5 to +1.5 min error per month At ambient temperature of 0°C: -3 to +1 min error per month				

\*2. Data will be refreshed at the set interval, regardless of the number of nodes.

\*3. "pps" means packets per second, i.e., the number of communications packets that can be sent or received in one second.

\*4. As the EtherNet/IP port implements the IGMP client, unnecessary multi-cast packets can be filtered by using a switching hub that supports IGMP Snooping.

Some function specifications are common with the NJ/NX-series Machine Automation Controller.  
 "CPU Unit" described in the *Function Specifications Supported by NY5□□-1* means "Controller" in the NY Series.

## Function Specifications Supported by NY5□□-1

Item			NY5□□-1		
Tasks	Function		I/O refreshing and the user program are executed in units that are called tasks. Tasks are used to specify execution conditions and execution priority.		
		Periodically executed tasks	Maximum number of primary periodic tasks	1	
			Maximum number of periodic tasks	3	
		Conditionally executed tasks	Maximum number of event tasks	32	
Execution conditions	When Activate Event Task instruction is executed or when condition expression for variable is met.				
Programming	POU (program organization units)	Programs	POUs that are assigned to tasks.		
		Function blocks	POUs that are used to create objects with specific conditions.		
		Functions	POUs that are used to create an object that determine unique outputs for the inputs, such as for data processing.		
	Programming languages	Types	Ladder diagrams *1 and structured text (ST)		
	Namespaces			A concept that is used to group identifiers for POU definitions.	
	Variables	External access of variables	Network variables	The function which allows access from the HMI, host computers, or other Controllers	
	Data types	Basic data types	Boolean	BOOL	
			Bit strings	BYTE, WORD, DWORD, LWORD	
			Integers	INT, SINT, DINT, LINT, UINT, USINT, UDINT, ULINT	
			Real numbers	REAL, LREAL	
			Durations	TIME	
			Dates	DATE	
			Times of day	TIME_OF_DAY	
			Date and time	DATE_AND_TIME	
			Text strings	STRING	
		Derivative data types		Structures, unions, enumerations	
		Structures	Function		A derivative data type that groups together data with different variable types.
			Maximum number of members		2048
			Nesting maximum levels		8
			Member data types		Basic data types, structures, unions, enumerations, array variables
	Unions	Specifying member offsets		You can use member offsets to place structure members at any memory locations.	
		Function		A derivative data type that groups together data with different variable types.	
		Maximum number of members		4	
	Enumerations	Member data types		BOOL, BYTE, WORD, DWORD, LWORD	
		Function		A derivative data type that uses text strings called enumerators to express variable values.	
	Data type attributes	Array specifications	Function	An array is a group of elements with the same data type. You specify the number (subscript) of the element from the first element to specify the element.	
			Maximum number of dimensions	3	
Maximum number of elements			65535		
Array specifications for FB instances			Supported.		
Range specifications			You can specify a range for a data type in advance. The data type can take only values that are in the specified range.		
Libraries			User libraries		
Motion control	Control modes		position control, velocity control, torque control		
	Axis types		Servo axes, virtual servo axes, encoder axes, and virtual encoder axes		
	Positions that can be managed		Command positions and actual positions		
	Single-axis	Single-axis position control	Absolute positioning	Positioning is performed for a target position that is specified with an absolute value.	
			Relative positioning	Positioning is performed for a specified travel distance from the command current position.	
			Interrupt feeding	Positioning is performed for a specified travel distance from the position where an interrupt input was received from an external input.	
		Single-axis velocity control	Cyclic synchronous absolute positioning	A positioning command is output each control period in Position Control Mode.	
			Velocity control	Velocity control is performed in Position Control Mode.	
		Single-axis torque control	Cyclic synchronous velocity control	A velocity command is output each control period in Velocity Control Mode.	
			Torque control	The torque of the motor is controlled.	

\*1. Inline ST is supported. (Inline ST is ST that is written as an element in a ladder diagram.)

		Item	NY5□□-1		
Motion control	Single-axis	Single-axis synchronized control	Starting cam operation	A cam motion is performed using the specified cam table.	
			Ending cam operation	The cam motion for the axis that is specified with the input parameter is ended.	
			Starting gear operation	A gear motion with the specified gear ratio is performed between a master axis and slave axis.	
			Positioning gear operation	A gear motion with the specified gear ratio and sync position is performed between a master axis and slave axis.	
			Ending gear operation	The specified gear motion or positioning gear motion is ended.	
			Synchronous positioning	Positioning is performed in sync with a specified master axis.	
			Master axis phase shift	The phase of a master axis in synchronized control is shifted.	
		Combining axes	The command positions of two axes are added or subtracted and the result is output as the command position.		
		Single-axis manual operation	Powering the servo	The Servo in the Servo Drive is turned ON to enable axis motion.	
			Jogging	An axis is jogged at a specified target velocity.	
		Auxiliary functions for single-axis control	Resetting axis errors	Axes errors are cleared.	
			Homing	A motor is operated and the limit signals, home proximity signal, and home signal are used to define home.	
			Homing with parameter	Specifying the parameter, a motor is operated and the limit signals, home proximity signal, and home signal are used to define home.	
			High-speed homing	Positioning is performed for an absolute target position of 0 to return to home.	
			Stopping	An axis is decelerated to a stop at the specified rate.	
			Immediately stopping	An axis is stopped immediately.	
			Setting override factors	The target velocity of an axis can be changed.	
			Changing the current position	The command current position or actual current position of an axis can be changed to any position.	
			Enabling external latches	The position of an axis is recorded when a trigger occurs.	
			Disabling external latches	The current latch is disabled.	
			Zone monitoring	You can monitor the command position or actual position of an axis to see when it is within a specified range (zone).	
	Enabling digital cam switches		You can turn a digital output ON and OFF according to the position of an axis.		
	Monitoring axis following error		You can monitor whether the difference between the command positions or actual positions of two specified axes exceeds a threshold value.		
	Resetting the following error		The error between the command current position and actual current position is set to 0.		
	Torque limit		The torque control function of the Servo Drive can be enabled or disabled and the torque limits can be set to control the output torque.		
	Slave Axis Position Compensation	This function compensates the position of the slave axis currently in synchronized control.			
	Cam monitor	Outputs the specified offset position for the slave axis in synchronous control.			
	Start velocity	You can set the initial velocity when axis motion starts.			
	Axes groups	Multi-axes coordinated control	Absolute linear interpolation	Linear interpolation is performed to a specified absolute position.	
			Relative linear interpolation	Linear interpolation is performed to a specified relative position.	
			Circular 2D interpolation	Circular interpolation is performed for two axes.	
		Auxiliary functions for multi-axes coordinated control	Axes group cyclic synchronous absolute positioning	A positioning command is output each control period in Position Control Mode.	
			Resetting axes group errors	Axes group errors and axis errors are cleared.	
			Enabling axes groups	Motion of an axes group is enabled.	
			Disabling axes groups	Motion of an axes group is disabled.	
			Stopping axes groups	All axes in interpolated motion are decelerated to a stop.	
			Immediately stopping axes groups	All axes in interpolated motion are stopped immediately.	
			Setting axes group override factors	The blended target velocity is changed during interpolated motion.	
			Reading axes group positions	The command current positions and actual current positions of an axes group can be read.	
		Changing the axes in an axes group	The Composition Axes parameter in the axes group parameters can be overwritten temporarily.		
		Common items	Cams	Setting cam table properties	The end point index of the cam table that is specified in the input parameter is changed.
				Saving cam tables	The cam table that is specified with the input parameter is saved in non-volatile memory in the CPU Unit.
Generating cam tables				The cam table that is specified with the input parameter is generated from the cam property and cam node.	
Parameters	Writing MC settings		Some of the axis parameters or axes group parameters are overwritten temporarily.		
	Changing axis parameters		You can access and change the axis parameters from the user program.		

		Item	NY5□□-1	
Motion control	Auxiliary functions	Count modes	You can select either Linear Mode (finite length) or Rotary Mode (infinite length).	
		Unit conversions	You can set the display unit for each axis according to the machine.	
		Acceleration/ deceleration control	Automatic acceleration/ deceleration control	Jerk is set for the acceleration/deceleration curve for an axis motion or axes group motion.
			Changing the acceleration and deceleration rates	You can change the acceleration or deceleration rate even during acceleration or deceleration.
		In-position check	You can set an in-position range and in-position check time to confirm when positioning is completed.	
		Stop method	You can set the stop method to the immediate stop input signal or limit input signal.	
		Re-execution of motion control instructions	You can change the input variables for a motion control instruction during execution and execute the instruction again to change the target values during operation.	
		Multi-execution of motion control instructions (Buffer mode)	You can specify when to start execution and how to connect the velocities between operations when another motion control instruction is executed during operation.	
		Continuous axes group motions (Transition mode)	You can specify the Transition Mode for multi-execution of instructions for axes group operation.	
		Monitoring functions	Software limits	Software limits are set for each axis.
			Following error	The error between the command current value and the actual current value is monitored for an axis.
			Velocity, acceleration rate, deceleration rate, torque, interpolation velocity, interpolation acceleration rate, and interpolation deceleration rate	You can set and monitor warning values for each axis and each axes group.
		Absolute encoder support	You can use an OMRON 1S-series Servomotor or G5-Series Servomotor with an Absolute Encoder to eliminate the need to perform homing at startup.	
Input signal logic inversion	You can inverse the logic of immediate stop input signal, positive limit input signal, negative limit input signal, or home proximity input signal.			
External interface signals		The Servo Drive input signals listed on the right are used.	Home signal, home proximity signal, positive limit signal, negative limit signal, immediate stop signal, and interrupt input signal.	
Unit (I/O) management	EtherCAT slaves	Maximum number of slaves	192	
Communications	Built-in EtherNet/IP port Internal Port	Communications protocol		TCP/IP, UDP/IP
		TCP/IP functions	CIDR	The function which performs IP address allocations without using a class (class A to C) of IP address.
			IP Forwarding	The function which forward IP packets between interfaces.
			Packet Filter #2	Check the IP packet, the function to determine whether to receive the source IP address and TCP port number.
			NAT	Function for transfer by converting the two IP address.
		CIP communications service	Tag data links	Programless cyclic data exchange is performed with the devices on the EtherNet/IP network.
			Message communications	CIP commands are sent to or received from the devices on the EtherNet/IP network.
		TCP/IP applications	Socket services	Data is sent to and received from any node on Ethernet using the UDP or TCP protocol. Socket communications instructions are used.
			FTP client	File can be read from or written to computers at other Ethernet nodes from the CPU Unit. FTP client communications instructions are used.
			FTP server	Files can be read from or written to the SD Memory Card in the CPU Unit from computers at other Ethernet nodes.
	SNMP agent		Built-in EtherNet/IP port internal status information is provided to network management software that uses an SNMP manager.	
	EtherCAT port	Supported services	Process data communications	A communications method to exchange control information in cyclic communications between the EtherCAT master and slaves. This communications method is defined by CoE.
			SDO communications	A communications method to exchange control information in noncyclic event communications between EtherCAT master and slaves. This communications method is defined by CoE.
		Network scanning		Information is read from connected slave devices and the slave configuration is automatically generated.
		DC (distributed clock)		Time is synchronized by sharing the EtherCAT system time among all EtherCAT devices (including the master).
		Packet monitoring		The frames that are sent by the master and the frames that are received by the master can be saved. The data that is saved can be viewed with WireShark or other applications.
		Enable/disable settings for slaves		The slaves can be enabled or disabled as communications targets.
		Disconnecting/connecting slaves		Temporarily disconnects a slave from the EtherCAT network for maintenance, such as for replacement of the slave, and then connects the slave again.
		Supported application protocol	CoE	SDO messages of the CAN application can be sent to slaves via EtherCAT.
	Communications instructions		The following instructions are supported. CIP communications instructions, socket communications instructions, SDO message instructions, FTP client instructions, and Modbus RTU protocol instructions.	

\*2. Internal Port only.

		Item	NY5□□-1	
System management	Event logs	Function	Events are recorded in the logs.	
		Maximum number of events	System event log	2,048
			Access event log	1,024
			User-defined event log	1,024
Debugging	Online editing	Single	Programs, function blocks, functions, and global variables can be changed online. Different operators can change different POU's across a network.	
	Forced refreshing		The user can force specific variables to TRUE or FALSE.	
		Maximum number of forced variables	Device variables for EtherCAT slaves	64
	MC test run		Motor operation and wiring can be checked from the Sysmac Studio.	
	Synchronizing		The project file in the Sysmac Studio and the data in the CPU Unit can be made the same when online.	
	Differentiation monitoring		Rising/falling edge of contacts can be monitored.	
		Maximum number of contacts		8
		Types	Single triggered trace	When the trigger condition is met, the specified number of samples are taken and then tracing stops automatically.
			Continuous trace	Data tracing is executed continuously and the trace data is collected by the Sysmac Studio.
		Maximum number of simultaneous data trace		4
		Maximum number of records		10,000
		Sampling	Maximum number of sampled variables	192 variables
		Timing of sampling		Sampling is performed for the specified task period, at the specified time, or when a sampling instruction is executed.
		Triggered traces		Trigger conditions are set to record data before and after an event.
			Trigger conditions	When BOOL variable changes to TRUE or FALSE Comparison of non-BOOL variable with a constant Comparison Method: Equals (=), Greater than (>), Greater than or equals (≥), Less Than (<), Less than or equals (≤), Not equal (≠)
		Delay	Trigger position setting: A slider is used to set the percentage of sampling before and after the trigger condition is met.	
Simulation			The operation of the CPU Unit is emulated in the Sysmac Studio.	
Reliability functions	Self-diagnosis	Controller errors	Levels	Major fault, partial fault, minor fault, observation, and information
			Maximum number of message languages	9 (Sysmac Studio) 2 (NS-series PT) *3
		User-defined errors	Function	User-defined errors are registered in advance and then records are created by executing instructions.
			Levels	8 levels
			Maximum number of message languages	9
Security	Protecting software assets and preventing operating mistakes	CPU unit names and serial IDs		When going online to a CPU Unit from the Sysmac Studio, the CPU Unit name in the project is compared to the name of the CPU Unit being connected to.
		Protection	User program transfer with no restoration information	You can prevent reading data in the CPU Unit from the Sysmac Studio.
			CPU unit write protection	You can prevent writing data to the CPU Unit from the Sysmac Studio or SD Memory Card.
			Overall project file protection	You can use passwords to protect .smc files from unauthorized opening on the Sysmac Studio.
			Data protection	You can use passwords to protect POU's on the Sysmac Studio.
		Verification of operation authority		Online operations can be restricted by operation rights to prevent damage to equipment or injuries that may be caused by operating mistakes.
			Number of groups	5
Verification of user program execution ID		The user program cannot be executed without entering a user program execution ID from the Sysmac Studio for the specific hardware (CPU Unit).		
Memory card functions	Location to store		Shared folder: The folder that exist on the HDD / SDD that Windows is running.	
	Application	Memory card operation instructions		You can access Memory Cards from instructions in the user program.
		File operations from the Sysmac Studio		You can perform file operations for Controller files in the Memory Card and read/write general-purpose document files on the computer.
		File operations from FTP Client/Server		You can store and read files by the FTP client function and FTP server function.
Backup functions	SD memory card backup functions	Operation	Using system-defined variables	You can use system-defined variables to backup or compare data.
			Memory card operations dialog box on Sysmac Studio	Backup and verification operations can be performed from the SD Memory Card Operations Dialog Box on the Sysmac Studio.
			Using instruction	Backup operation can be performed by using instruction.
		Protection	Prohibiting backing up data to the SD memory card	Prohibit SD Memory Card backup functions.
	Sysmac Studio controller backup functions		Backup, restore, and verification operations for Units can be performed from the Sysmac Studio.	

\*3. NS-series PT is no longer available to order.

## Performance Specifications

Item		NY5□□-1□00-0□□□4	NY5□□-1□00-1□□□4		
Main system	CPU	CPU type	Intel® Core™ i5-7440EQ		
		Cores / Threads	4 / 4		
		CPU base frequency	2.9 GHz		
		Cache	6 MB		
		Cooling details	Requires active cooling (fan)		
		Intel CPU category	Industrial (100% operation minimal 10yr)		
	Memory	Memory size *1	8 or 32 GB		
		Memory type	DDR4 (non ECC)		
	Trusted platform module (TPM)		Available		
Graphics controller		Intel® HD Graphics. Up to two independent screens. Intel® HD Graphics 630			
Watchdog		Yes			
Operating system	Windows OS	Windows 10 IoT Enterprise 2019 LTSC - 64 bit			
Storage devices	Drives *1	Hard disk drive		---	
		Solid state drive	SLC type	---	64 GB Serial ATA 3.1
			MLC type	128 GB, 256 GB Serial ATA 3.1 CFast	128 GB Serial ATA 3.1
			3DTLC type	---	1 TB Serial ATA 3.1
	Drive bay (HDD/SSD) *2		CFast slot	2	
Connectors	Power connector		24 VDC		
	I/O connector		2 inputs (Power ON/OFF Input and UPS Mode Input) and 1 output (Power Status Output)		
	USB 2.0 Type-A	Number of ports	2		
		Maximum current	500 mA		
		Maximum cable length	5 m		
	USB 3.0 Type-A	Number of ports	2		
		Maximum current	900 mA		
		Maximum cable length	3 m		
	Ethernet connectors	Number of available ports	3		
		Physical layer	10BASE-T, 100BASE-TX or 1000BASE-T		
	DVI-I connector	Video interface	Digital or analog		
Resolution		Up to 1,920 x 1,200 pixels at 60 Hz			
Maximum DVI cable length		Dependent upon connected monitor type and resolution			
Optional connector (select one per system)	RS-232C		---	Standard SUBD9 connector (Non-Isolated)	
	DVI-D	Video interface	---	Digital only	
		Resolution	---	Up to 1,920 x 1,200 pixels at 60 Hz	
		Maximum DVI cable length	---	Dependent upon connected monitor type and resolution	
	NY Monitor Link	Video interface	Digital only		
		Resolution	1,280 x 800 pixels at 60 Hz		
		Connector type	RJ45		
		Cable shielding, type and max. length	S/FTP, Cat.6A, 100m		
USB data throughput	280 Mbps max.				
PCIe Card Slot	Configuration		---	X4 (4 lanes) up to Gen 3	
	Card height		---	Standard height cards, 4.20 inches (106.7 mm) *3	
	Card length		---	Half length cards, 6.6 inches (167.65 mm)	
Battery	Model		CJ1W-BAT01		
	Service life		5 years at 25°C		
Fan unit	Model		NY000-AF00		
	Service life		70,000 hours of continuous operation at 40°C with 15% to 65% relative humidity		
LED		PWR, ERR, HDD, RUN			

\*1. Not all combinations are possible or standard available. Please contact your Omron representative to discuss the possibilities.

\*2. Depending on the model one or two drives are supported.

\*3. Low profile cards, 2.536 inches (64.4 mm) are not supported.

## Display Specifications

Item		Specifications				
		12.1 Inch models	15.4 Inch models	18.5 inch models		
Display	Display panel *1	Display device	TFT LCD			
		Screen size	12.1 inches	15.4 inches	18.5 inches	
		Surface treatment	Anti glare treatment			
		Surface hardness	Mohs scale: 5 - 6			
		Resolution	1,280 × 800 pixels at 60 Hz (horizontal × vertical)		1,920 × 1,080 pixels at 60 Hz (horizontal × vertical)	
		Ratio	16 × 10		16 × 9	
		Colors	16,770,000 colors			
		Effective display area	261 × 163 mm (horizontal × vertical)	331 × 207 mm (horizontal × vertical)	409 × 230 mm (horizontal × vertical)	
		View angles	Left: 60°, Right: 60°, Top: 60°, Bottom: 60°		Left: 89°, Right: 89°, Top: 89°, Bottom: 89°	
		Typical LCD Brightness (initial)	1500 cd/m <sup>2</sup>	400 cd/m <sup>2</sup>	500 cd/m <sup>2</sup>	
		Life	50,000 hours min. *2			
		Brightness adjustment	200 levels *3			
	Touch	Technology	Projected capacitive			
		Touch resolution	Touch accuracy 1.5% (4-5 mm)			
		Multitouch	Up to 5 simultaneous touches			
		Features	Water detection *4, hand palm rejection *5, gloves *6			
		Life	50,000,000 operations min.			
	Front housing	EMC	Correct touchscreen operation is possible within allowable EMC immunity conditions			
		Material	Aluminium			
		Finish *7	Black paint		Black paint or Nickel plating	

**Note:** Industrial Panel PC type only.

\*1. There may be some defective pixels in the display. This is not a fault as long as the numbers of defective light and dark pixels fall within the following standard range: light and dark pixels 10 or less. (There must not be 3 consecutive light/dark pixels.)

\*2. This is the estimated time before brightness is reduced by half at room temperature and humidity.  
The life expectancy is drastically shortened if used at high temperatures.

\*3. If the brightness is set to very dark, it causes flickering or the screen will be too dark to use.

\*4. If water is detected the touch functionality will not be available.

\*5. If a palm is detected that specific area is neglected.

\*6. The touchscreen can be operated when wearing gloves. Check correct usage of the gloves before using them.

\*7. Black paint:

Industrial paint based on durable polyester resin with very high weathering resistance characteristics. Matt black - matching RAL9005.

Nickel Plating:

A product with 'Material Finish' being 'Aluminium, Nickel Plated' conforms to ASTM B733-15, SC2.

The nature of nickel plating on our frames can show light disturbance on the surface.



## Electrical Specifications

Item	NY51□-1□00-0□□□4	NY51□-1□00-1□□□4	NY53□-1□00-0□1□4 NY53□-1□00-0□2□4	NY53□-1□00-0□3□4		
	Intel® Core™ i5-7440EQ					
Rated power supply voltage	24 VDC, non-isolated					
Allowable power supply voltage range	20.4 to 28.8 VDC					
Grounding method	Ground to less than 100 Ω					
Inrush current	At 24 VDC: 12 A / 6 ms max. for cold start at room temperature					
Overvoltage category	JIS B3502 and IEC 61131-2: Category II					
EMC immunity level	IEC 61131-2: Zone B					
RTC accuracy	At ambient temperature of 55°C: -3.5 to +0.5 min error per month At ambient temperature of 25°C: -1.5 to +1.5 min error per month At ambient temperature of 0°C: -3 to +1 min error per month					
Power button life	100,000 operations					
Battery life	5 years at 25°C (for battery CJ1W-BAT01)					
Fan life	8 years of continuous operation at 40°C					
Power consumption *	Maximum power consumption including drives and expansions	85 W	106 W	101 W	123 W	
	Maximum power consumption excluding drives and expansions	70 W	73W	86 W	108 W	
	Drives	SSD SLC 32 GB	-	-	-	-
		SSD SLC 64 GB	-	2 W	-	-
		SSD MLC 128 GB	-	2 W	-	-
		SSD 3DTLC 1 TB	-	3 W	-	-
		CFast MLC 128 GB	1 W	-	1 W	-
	CFast MLC 256 GB	1 W	-	1 W	-	
	Expansions	USB	14 W max. ((2 x 500 mA at 5 V) + (2 x 900 mA at 5 V))			
PCIe		-	15 W max.	-	-	

**Note:** Refer to the NY-series IPC Machine Controller Industrial Panel PC Hardware User's Manual (W557) or the NY-series IPC Machine Controller Industrial Box PC Hardware User's Manual (W556) for detail.

\* The total power consumption is the sum of the power consumption of all items that are installed in your Industrial PC.  
To guarantee S8BA UPS operation in combination with our IPC, the specified combination of UPS and power-supply must be used.

Item	Minimum power requirements			
Power supply	240 W	240 W	240 W	240 W
UPS	120 W	120 W	120 W	240 W

## Environmental Specifications

Item	Specifications		
	Industrial Box PC	Industrial Panel PC	
Operation environment	Ambient operating temperature *1	0 to 55°C	
	Ambient storage temperature *1	-20 to 70°C	
	Ambient operating humidity *1	10% to 90% with no condensation	
	Ambient storage humidity *1	10% to 90% with no condensation	
	Operating atmosphere	No corrosive gases	
	Altitude	2,000 m max.	
	Noise resistance (during operation)	Conforms to IEC61000-4-4, 2 kV (power lines)	
	Vibration resistance (during operation)	<p>Conforms to IEC 60068-2-6.</p> <ul style="list-style-type: none"> <li>For a Box PC with an SSD: 5 to 8.4 Hz with 3.5 mm single amplitude and 8.4 to 150 Hz with 9.8 m/s<sup>2</sup> for 10 times each in X, Y and Z directions.</li> <li>For a Box PC with a HDD the vibration resistance depends on the mounting orientation *2.</li> </ul>	<p>The vibration resistance depends on the storage device(s):</p> <ul style="list-style-type: none"> <li>For a Panel PC with only SSD storage devices: 5 to 8.4Hz with 3.5 mm single amplitude and 8.4 to 150 Hz with 9.8 m/s<sup>2</sup> for 10 times each in X, Y and Z directions. Conforms to IEC 60068-2-6.</li> <li>For a Panel PC with one or more HDD storage devices the Panel PC must be installed in a vibration free environment. *3</li> </ul>
	Shock resistance (during operation)	Conforms to IEC 60068-2-27. 147 m/s <sup>2</sup> , 3 times in each X, Y and Z directions	
	Installation method	Book mount, Wall mount	Mount on panel
Degree of protection *4	–	Front of Monitor: IP65	
Pollution degree	2 or less: Meets IEC 61010-2-201.		
Applicable standards *5	EU Directives: EMC Directive 2014/30/EU (EN 61131-2) and RoHS Directive KC Registration, RCM, cULus		

\*1. The allowed ambient operating temperature and ambient humidity depend on product type, CPU type, mounting orientation, and storage device type.

\*2. Vibration resistance depends on the Box PC's mounting orientation and storage device type.

Mounting Orientation	SSD	HDD
Book	9.8 m/s <sup>2</sup>	2.5 m/s <sup>2</sup>
Wall		4.9 m/s <sup>2</sup>

\*3. A Panel PC with one or more HDD storage devices should not be used in applications subject to vibration.

Examples of applications subject to vibration:

- AGV (Automated Guided Vehicles)
- Rail vehicle
- Stacker crane
- Elevator
- Tableting machine
- Connector pin assembling machine
- Bending machine

Ensure your Panel PC with HDD does not vibrate. When in doubt use a Panel PC with SSD storage devices.

\*4. The Panel PC may not operate properly in locations subjected to oil splashes for extended periods of time. (Industrial Panel PC type only)

\*5. Refer to the OMRON website ([www.ia.omron.com](http://www.ia.omron.com)) or contact your OMRON representative for the most recent applicable standards for each model.

## Storage Device Specifications

Item	Specifications							
Model	NY000-AS00 *4	NY000-AS01	NY000-AS03	NY000-AS04	NY000-AS07	NY000-AH00 *1*4	NY000-AT01	NY000-AT02
Capacity	32 GB	64 GB	64 GB	128 GB	1 TB	320 GB	128 GB	256 GB
Type	SSD (SLC)			SSD (MLC)	SSD (3DTLC)	HDD	CFast (MLC)	
S.M.A.R.T. support	Yes							
Rotation speed	-					5,400 r/min	-	
Interface	Serial ATA 3.1				Serial ATA 3.0		Serial ATA 3.1	
Sustained standard read speed	Up to 160 MB/s		Up to 500 MB/s	Up to 530 MB/s	Up to 550 MB/s	-	Up to 530 MB/s	
Sustained standard write speed	Up to 150 MB/s		Up to 370 MB/s	Up to 190 MB/s	Up to 340 MB/s	-	Up to 190 MB/s	Up to 210 MB/s
Operating temperature	0 to 70°C					5 to 55°C	-40 to 85°C	
Operating humidity	10% to 95% (with no condensation)		10% to 85% (with no condensation)	10% to 95% (with no condensation)		<ul style="list-style-type: none"> <li>• 10% to 95% (with no condensation)</li> <li>• 29°C wet-bulb temperature max.</li> </ul>	10% to 95% (with no condensation)	
Storage temperature	-40 to 100°C		-45 to 90°C	-55 to 95°C		-40 to 65°C	-55 to 95°C	
Storage humidity	10% to 95% (with no condensation)					<ul style="list-style-type: none"> <li>• 8% to 90% (with no condensation)</li> <li>• 40°C wet-bulb temperature max.</li> </ul>	10% to 95% (with no condensation)	
Life	1,500 TB written	3,000 TB written	1,900 TB written	208 TB written	1,000 TB written	Approximately 5 years or 20,000 powered-ON hours (whichever comes first) under the following conditions: <ul style="list-style-type: none"> <li>• 25°C at 101.3 kPa</li> <li>• Less than 333 powered-ON hours/month *2</li> <li>• Less than 20% operation while powered-ON *3</li> <li>• Less than 1.30 x 10<sup>6</sup> seeks/month</li> </ul>	208 TB written	417 TB written

**Note:** Orders for NY000-AS02 are no longer accepted, as of November 30, 2018.

\*1. For a Panel PC with an HDD: this device can only be installed in a vibration free environment only.

\*2. Powered-ON hours include sleep and standby modes.

\*3. Operation includes seeking, writing, and reading functions.

\*4. End of Life: only available for support purpose

## Dimensions

### Industrial Box PC type

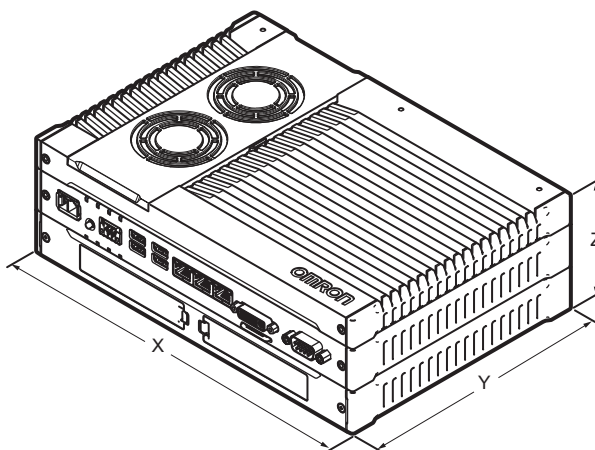

Item	NY51□-1□00-1	NY51□-1□00-0
<b>Dimensions</b>	Width X = 282 mm Depth Y = 195 mm. Y = 200 mm including the DVI connectors. Height Z = 88.75 mm	Width X = 282 mm Depth Y = 195 mm. Y = 200 mm including the DVI connectors. Height Z = 56 mm
<b>Weight</b>	3.8 kg	2.6 kg

### Bracket Specifications

The metal mounting brackets mount your Industrial Box PC and they are the connection for the functional ground.

Use metal screws with a diameter of 4 mm or 5 mm to mount the brackets.

Mounting screw locations for book mount and wall mount orientation:

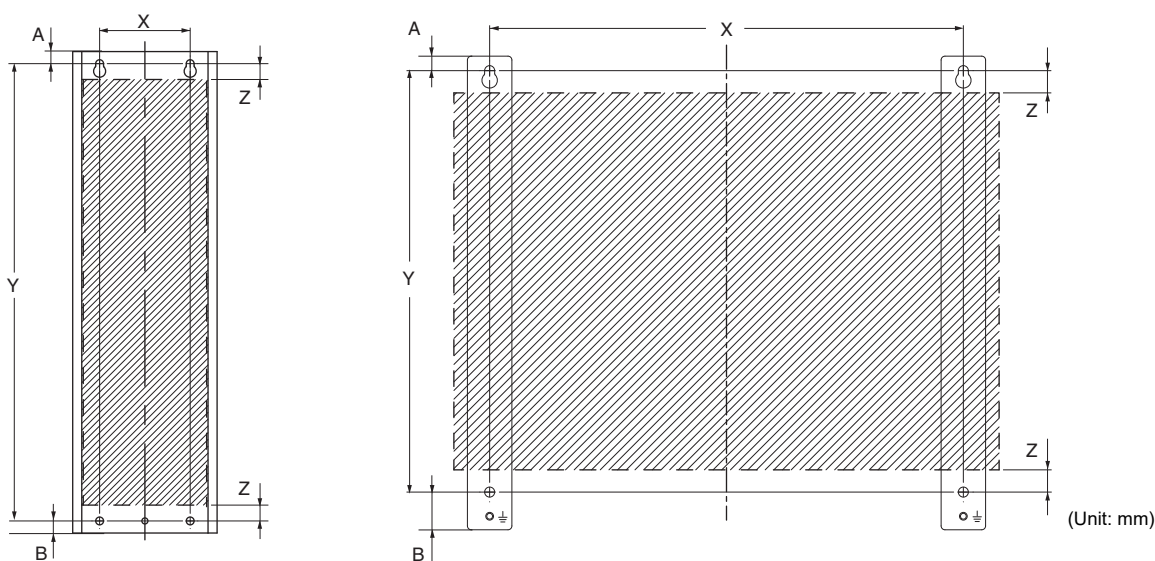

Model	Bracket type	Bracket ID	Drill Specifications			Product Dimensions			
			Hole Distance X	Hole Distance Y	Distance Z	Bracket Width	Bracket Height	Top to hole A	Top to hole B
All	Wall mount	NY000-AB01	245 mm	218 mm	12 mm	23 mm	245 mm	7.5 mm	19.5 mm
NY51□-□□□□-1	Book mount	NY000-AB00	60 mm	303 mm	11 mm	96 mm	319 mm	8 mm	8 mm
NY51□-□□□□-0	Book mount	NY000-AB05	25 mm	303 mm	11 mm	63 mm	339 mm	8 mm	28 mm

## Industrial Panel PC type

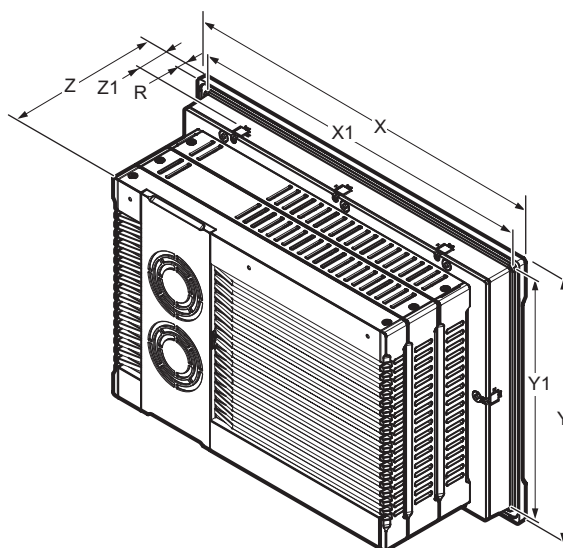

Item	Specifications				
	12.1 Inch		15.4 Inch		18.5 inch
	NY53□-1□00-1	NY53□-1□00-0	NY53□-1□00-1	NY53□-1□00-0	NY53□-1□00-0
<b>Panel cutout dimensions</b>	Cutout Width X1 = 314 <sup>-0</sup> +1 mm Cutout Height Y1 = 216 <sup>-0</sup> +1 mm		Cutout Width X1 = 383 <sup>-0</sup> +1 mm Cutout Height Y1 = 259 <sup>-0</sup> +1 mm		Cutout Width X1 = 463 <sup>-0</sup> +1 mm Cutout Height Y1 = 285 <sup>-0</sup> +1 mm
<b>Panel thickness range *</b>	Panel thickness range Z1 = 1.6 to 6.0 mm				
<b>Dimensions</b>	Width X = 332 mm Height Y = 234 mm Depth Z = 121 mm	Width X = 332 mm Height Y = 234 mm Depth Z = 88 mm	Width X = 401 mm Height Y = 277 mm Depth Z = 121 mm	Width X = 401 mm Height Y = 277 mm Depth Z = 88 mm	Width X = 482 mm Height Y = 304 mm Depth Z = 88 mm
<b>Monitor thickness in front of panel</b>	Rim thickness R = 8.0 mm				
<b>Weight</b>	6.1 kg	5.1 kg	7.2 kg	6.0 kg	7.0 kg

\* The minimum panel thickness depends on the panel material.

## Bracket Specifications

Without handle

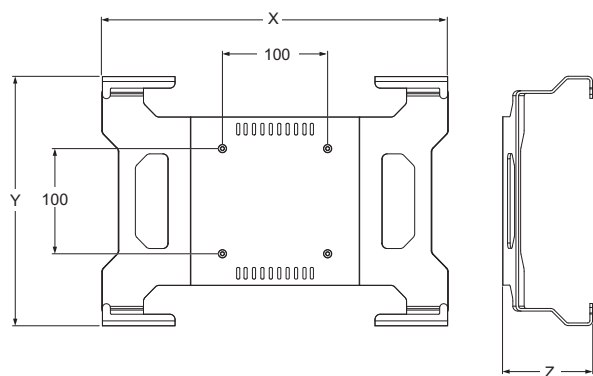

With handle NY000-AB12

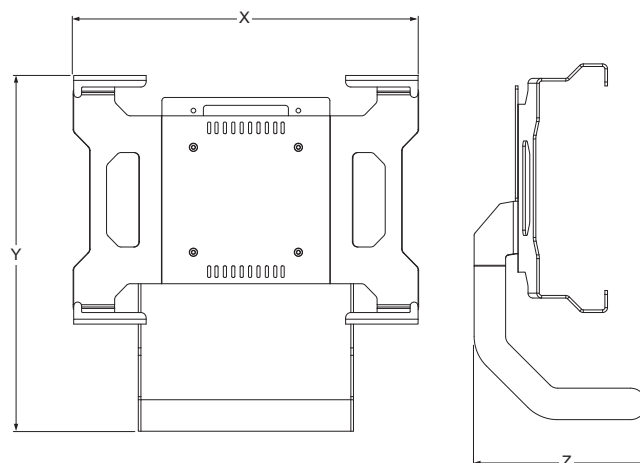

Model	Bracket type	Bracket ID	Without handle			With handle NY000-AB12		
			Bracket width X	Bracket height Y	Bracket depth Z	Bracket width X	Bracket height Y	Bracket depth Z
NYM12W	Vesa mount	NY000-AB06	328 mm	237 mm	86 mm	328 mm	339 mm	164 mm
NYM15W	Vesa mount	NY000-AB07	397 mm	280 mm	86 mm	397 mm	381 mm	164 mm
NYM19W	Vesa mount	NY000-AB08	478 mm	306 mm	83 mm	478 mm	409 mm	164 mm
NY53□-1□00-0□1□4	Vesa mount	NY000-AB09	328 mm	237 mm	118 mm	328 mm	339 mm	164 mm
NY53□-1□00-0□2□4	Vesa mount	NY000-AB10	397 mm	280 mm	118 mm	397 mm	381 mm	164 mm
NY53□-1□00-0□3□4	Vesa mount	NY000-AB11	478 mm	306 mm	98 mm	478 mm	409 mm	164 mm

## Version Information

### Unit Versions

Units	Models	Unit Version
IPC Machine Controller	NY5□2-1□00-□□□□1	Unit version 1.12 or later
	NY5□2-1□00-□□□□4	Unit version 1.24 or later

### Unit Versions and Programming Devices Supported by NY5□□-1/NY5□□-5

The following tables show the relationship between unit versions and Sysmac Studio versions.

#### Unit Versions and Programming Devices

Unit Version *	Corresponding version of Sysmac Studio
1.26	1.46 or higher
1.24	1.45 or higher
1.21	1.29 or higher
1.19	1.24 or higher
1.18	1.23 or higher
	1.22 or higher
1.16	1.20 or higher
1.14	1.19 or higher
	1.18 or higher
1.12	1.17 or higher

\* There is no NY5□2-1□00-□□□□1 with unit version 1.11 or earlier.

There is no NY5□2-1□00-□□□□1 with unit version 1.19. There is no NY5□2-1□00-□□□□4 with unit version 1.24 or earlier.

**Note:** If you use a lower version of the Sysmac Studio, you can use only the functions of the unit version of the unit that corresponds to the Sysmac Studio version.

If you use a unit with an earlier version, select the unit version of the connected unit or an earlier unit version in the Select Device Area of the Project Properties Dialog Box on the Sysmac Studio. You can use only the functions that are supported by the unit version of the connected unit.

## Functions That Were Added or Changed for Each Unit Version

- Additions and Changes to Basic Instructions and Motion Control Instructions  
For details, refer to the NY-series Instructions Reference Manual (Cat. No. W560) and NY-series Motion Control Instructions Reference Manual (Cat. No. W561).
- Additions and Changes to Controller Events  
For details, refer to the NY-series Troubleshooting Manual (Cat. No. W564).
- Additions and Changes to System-defined Variables  
For details, refer to the NY-series IPC Machine Controller Industrial Panel PC / Industrial Box PC Software User's Manual (Cat. No. W558).

## Related Manuals

Refer to the *Related Manuals* in the data sheet of the NY-series Industrial Box PC or NY-series Industrial Panel PC for the Related Manuals.

Manual name	Cat. No.	Model numbers	Application	Description
Industrial Panel PC User's Manual	W555	NYP27-□□□□-19WC1□□□ NYP27-□□□□-15WC1□□□ NYP27-□□□□-12WC100□ NYP35-□□□□-15WC100□ NYP35-□□□□-12WC100□ NYP2C-□□□□-15WC100□ NYP2C-□□□□-12WC100□ NYP35-□□□□-19WC1□□□ NYP2C-□□□□-19WC1□□□	Learning all basic information about the Industrial Panel PC. This includes introductory information with features, hardware overview, software overview, specifications, mounting, wiring, connecting, operating and maintaining the Industrial Panel PC.	An introduction to the Industrial Panel PC is provided along with the following information: <ul style="list-style-type: none"> <li>• Overview</li> <li>• Hardware</li> <li>• Software</li> <li>• Specifications</li> <li>• Installation</li> <li>• Operating Procedures</li> <li>• Maintenance</li> </ul>
NY-series IPC Machine Controller Industrial Panel PC Hardware User's Manual	W557	NY532-□□□□	Learning the basic specifications of the NY-series Industrial Panel PCs, including introductory information, designing, installation, and maintenance. Mainly hardware information is provided.	An introduction to the entire NY-series system is provided along with the following information on the Industrial Panel PC. <ul style="list-style-type: none"> <li>• Features and system configuration</li> <li>• Introduction</li> <li>• Part names and functions</li> <li>• General specifications</li> <li>• Installation and wiring</li> <li>• Maintenance and inspection</li> </ul>
NY-series IPC Machine Controller Industrial Box PC Hardware User's Manual	W556	NY512-□□□□	Learning the basic specifications of the NY-series Industrial Box PCs, including introductory information, designing, installation, and maintenance. Mainly hardware information is provided.	An introduction to the entire NY-series system is provided along with the following information on the Industrial Box PC. <ul style="list-style-type: none"> <li>• Features and system configuration</li> <li>• Introduction</li> <li>• Part names and functions</li> <li>• General specifications</li> <li>• Installation and wiring</li> <li>• Maintenance and inspection</li> </ul>
NY-series IPC Machine Controller Industrial Panel PC / Industrial Box PC Setup User's Manual	W568	NY532-□□□□ NY512-□□□□	Learning the initial settings of the NY-series Industrial PCs and preparations to use Controllers.	The following information is provided on an introduction to the entire NY-series system. <ul style="list-style-type: none"> <li>• Two OS systems</li> <li>• Initial settings</li> <li>• Industrial PC Support Utility</li> <li>• NYCompolet</li> <li>• Industrial PC API</li> <li>• Backup and recovery</li> </ul>
NY-series IPC Machine Controller Industrial Panel PC / Industrial Box PC Software User's Manual	W558	NY532-□□□□ NY512-□□□□	Learning how to program and set up the Controller functions of an NY-series Industrial PC.	The following information is provided on NY-series Machine Automation Control Software. <ul style="list-style-type: none"> <li>• Controller operation</li> <li>• Controller features</li> <li>• Controller settings</li> <li>• Programming based on IEC 61131-3 language specifications</li> </ul>
NY-series Instructions Reference Manual	W560	NY532-□□□□ NY512-□□□□	Learning detailed specifications on the basic instructions of an NY-series Industrial PC.	The instructions in the instruction set (IEC 61131-3 specifications) are described.
NY-series IPC Machine Controller Industrial Panel PC / Industrial Box PC Motion Control User's Manual	W559	NY532-□□□□ NY512-□□□□	Learning about motion control settings and programming concepts of an NY-series Industrial PC.	The settings and operation of the Controller and programming concepts for motion control are described.
NY-series Motion Control Instructions Reference Manual	W561	NY532-□□□□ NY512-□□□□	Learning about the specifications of the motion control instructions of an NY-series Industrial PC.	The motion control instructions are described.
NY-series IPC Machine Controller Industrial Panel PC / Industrial Box PC Built-in EtherCAT® Port User's Manual	W562	NY532-□□□□ NY512-□□□□	Using the built-in EtherCAT port in an NY-series Industrial PC	Information on the built-in EtherCAT port is provided. This manual provides an introduction and provides information on the configuration, features, and setup.
NY-series IPC Machine Controller Industrial Panel PC / Industrial Box PC Built-in EtherNet/IP™ Port User's Manual	W563	NY532-□□□□ NY512-□□□□	Using the built-in EtherNet/ IP port in an NY-series Industrial PC.	Information on the built-in EtherNet/IP port is provided. Information is provided on the basic setup, tag data links, and other features.
NY-series Troubleshooting Manual	W564	NY532-□□□□ NY512-□□□□	Learning about the errors that may be detected in an NY-series Industrial PC.	Concepts on managing errors that may be detected in an NY-series Controller and information on individual errors are described.
Sysmac Studio Version 1 Operation Manual	W504	SYSMAC-SE2□□□	Learning about the operating procedures and functions of the Sysmac Studio.	Describes the operating procedures of the Sysmac Studio.
UPS S8BA User's Manual	U702	S8BA	Learning the information that is necessary to use the Uninterruptible Power Supply (UPS) Unit.	An introduction to the UPS is provided along with the following information: <ul style="list-style-type: none"> <li>• Overview</li> <li>• Preparation</li> <li>• Installation and Connection</li> <li>• Check and Start Operation</li> <li>• Maintenance and Inspection</li> <li>• Shutdown Processing</li> <li>• I/O Signal Functions</li> <li>• Troubleshooting</li> </ul>

## Terms and Conditions Agreement

### Read and understand this catalog.

Please read and understand this catalog before purchasing the products. Please consult your OMRON representative if you have any questions or comments.

### Warranties.

(a) Exclusive Warranty. Omron's exclusive warranty is that the Products will be free from defects in materials and workmanship for a period of twelve months from the date of sale by Omron (or such other period expressed in writing by Omron). Omron disclaims all other warranties, express or implied.

(b) Limitations. OMRON MAKES NO WARRANTY OR REPRESENTATION, EXPRESS OR IMPLIED, ABOUT NON-INFRINGEMENT, MERCHANTABILITY OR FITNESS FOR A PARTICULAR PURPOSE OF THE PRODUCTS. BUYER ACKNOWLEDGES THAT IT ALONE HAS DETERMINED THAT THE PRODUCTS WILL SUITABLY MEET THE REQUIREMENTS OF THEIR INTENDED USE.

Omron further disclaims all warranties and responsibility of any type for claims or expenses based on infringement by the Products or otherwise of any intellectual property right. (c) Buyer Remedy. Omron's sole obligation hereunder shall be, at Omron's election, to (i) replace (in the form originally shipped with Buyer responsible for labor charges for removal or replacement thereof) the non-complying Product, (ii) repair the non-complying Product, or (iii) repay or credit Buyer an amount equal to the purchase price of the non-complying Product; provided that in no event shall Omron be responsible for warranty, repair, indemnity or any other claims or expenses regarding the Products unless Omron's analysis confirms that the Products were properly handled, stored, installed and maintained and not subject to contamination, abuse, misuse or inappropriate modification. Return of any Products by Buyer must be approved in writing by Omron before shipment. Omron Companies shall not be liable for the suitability or unsuitability or the results from the use of Products in combination with any electrical or electronic components, circuits, system assemblies or any other materials or substances or environments. Any advice, recommendations or information given orally or in writing, are not to be construed as an amendment or addition to the above warranty.

See <http://www.omron.com/global/> or contact your Omron representative for published information.

### Limitation on Liability: Etc.

OMRON COMPANIES SHALL NOT BE LIABLE FOR SPECIAL, INDIRECT, INCIDENTAL, OR CONSEQUENTIAL DAMAGES, LOSS OF PROFITS OR PRODUCTION OR COMMERCIAL LOSS IN ANY WAY CONNECTED WITH THE PRODUCTS, WHETHER SUCH CLAIM IS BASED IN CONTRACT, WARRANTY, NEGLIGENCE OR STRICT LIABILITY.

Further, in no event shall liability of Omron Companies exceed the individual price of the Product on which liability is asserted.

### Suitability of Use.

Omron Companies shall not be responsible for conformity with any standards, codes or regulations which apply to the combination of the Product in the Buyer's application or use of the Product. At Buyer's request, Omron will provide applicable third party certification documents identifying ratings and limitations of use which apply to the Product. This information by itself is not sufficient for a complete determination of the suitability of the Product in combination with the end product, machine, system, or other application or use. Buyer shall be solely responsible for determining appropriateness of the particular Product with respect to Buyer's application, product or system. Buyer shall take application responsibility in all cases.

NEVER USE THE PRODUCT FOR AN APPLICATION INVOLVING SERIOUS RISK TO LIFE OR PROPERTY OR IN LARGE QUANTITIES WITHOUT ENSURING THAT THE SYSTEM AS A WHOLE HAS BEEN DESIGNED TO ADDRESS THE RISKS, AND THAT THE OMRON PRODUCT(S) IS PROPERLY RATED AND INSTALLED FOR THE INTENDED USE WITHIN THE OVERALL EQUIPMENT OR SYSTEM.

### Programmable Products.

Omron Companies shall not be responsible for the user's programming of a programmable Product, or any consequence thereof.

### Performance Data.

Data presented in Omron Company websites, catalogs and other materials is provided as a guide for the user in determining suitability and does not constitute a warranty. It may represent the result of Omron's test conditions, and the user must correlate it to actual application requirements. Actual performance is subject to the Omron's Warranty and Limitations of Liability.

### Change in Specifications.

Product specifications and accessories may be changed at any time based on improvements and other reasons. It is our practice to change part numbers when published ratings or features are changed, or when significant construction changes are made. However, some specifications of the Product may be changed without any notice. When in doubt, special part numbers may be assigned to fix or establish key specifications for your application. Please consult with your Omron's representative at any time to confirm actual specifications of purchased Product.

### Errors and Omissions.

Information presented by Omron Companies has been checked and is believed to be accurate; however, no responsibility is assumed for clerical, typographical or proofreading errors or omissions.

2024.11

In the interest of product improvement, specifications are subject to change without notice.

**OMRON Corporation**  
Industrial Automation Company

<http://www.ia.omron.com/>

(c)Copyright OMRON Corporation 2024 All Right Reserved.