

Safety Light Curtain F3SJ-B□□□□N25-01T Series

Quick Installation Manual



Relevant manual	Cat. No.
Safety Light Curtain F3SJ-B-01T User's Manual	SCHG-735

Introduction

Thank you for purchasing the F3SJ-B□□□□N25-01T Series Safety Light Curtain (hereinafter referred to as the "F3SJ-B-01T").



This document is a brief description from wiring to pre-operation checklists / maintenance checklists of F3SJ-B-01T.

For details, download and read F3SJ-B-01T operation manual and user's manual from Omron's website. <https://industrial.omron.us/en/home>

Table of Contents

1. What is Included	1
2. System Components	2
3. Light Curtain Setup Flow	2
4. Function Selection Flow Chart	2
5. Wiring Examples	3
5-1. Auto reset mode, external test used	3
6. Mounting and Beam Alignment	4
6-1. Mutual Interference Prevention	4
6-2. Distance from Reflective Surfaces	4
6-3. Safety Distance	4
6-4. External dimensions to attach the top/bottom brackets (F39-LJB1) and intermediate brackets (F39-LJB2) ...	5
6-5. Mounting and Beam Alignment	7
7. Pre-Operation Checklists / Maintenance Checklists	10
Suitability for Use/Contact Information	12

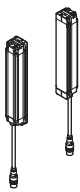
1. What is Included

Product	Pcs & Details						
F3SJ-B□□□□N25-01T main unit 	Emitter x 1, Receiver x 1 Functional Settings <table border="1"> <thead> <tr> <th>Function</th> <th>Factory Default Setting</th> </tr> </thead> <tbody> <tr> <td>External Test</td> <td>Enabled when test input line open or 1/2 Vs to Vs*1 applied</td> </tr> <tr> <td>Auxiliary Output</td> <td>Control Output Information (Output Inversion Function: Enabled)</td> </tr> </tbody> </table> <p>*1 Vs here means the voltage value under use environment.  For details, refer to <i>F3SJ-B-01T series user's manual</i>.</p>	Function	Factory Default Setting	External Test	Enabled when test input line open or 1/2 Vs to Vs*1 applied	Auxiliary Output	Control Output Information (Output Inversion Function: Enabled)
Function	Factory Default Setting						
External Test	Enabled when test input line open or 1/2 Vs to Vs*1 applied						
Auxiliary Output	Control Output Information (Output Inversion Function: Enabled)						
Operation Manual	3						
Quick Installation Manual (this document)	1						

 For ratings/specifications, input/output circuit, LED indicator status and troubleshooting, refer to *Safety Light Curtain F3SJ-B-01T Series User's Manual*.

2. System Components

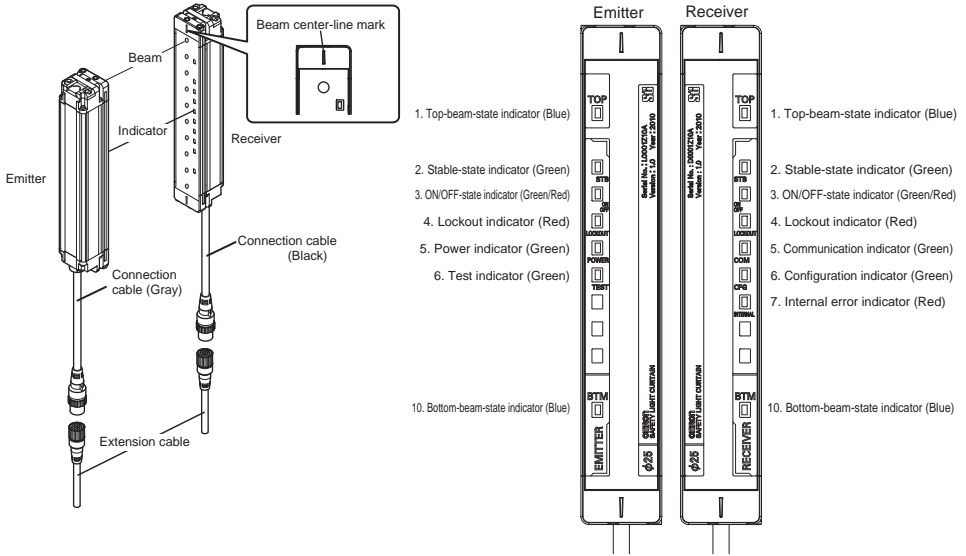

3. Light Curtain Setup Flow

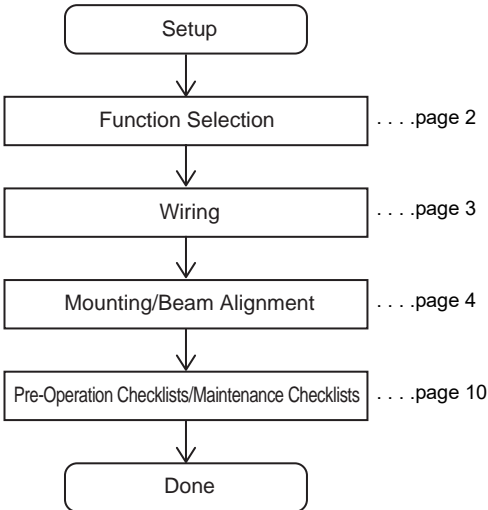

4. Function Selection Flow Chart

Wiring depends on the function to be used. Shown below are the available functions.

- External Test Function
- Auxiliary Output Function

For details, refer to *F3SJ-B-01T series user's manual*.



5. Wiring Examples



For wiring examples of input/output circuit and other wiring examples than below, refer to *F3SJ-B-01T series user's manual*.

5-1. Auto reset mode, external test used

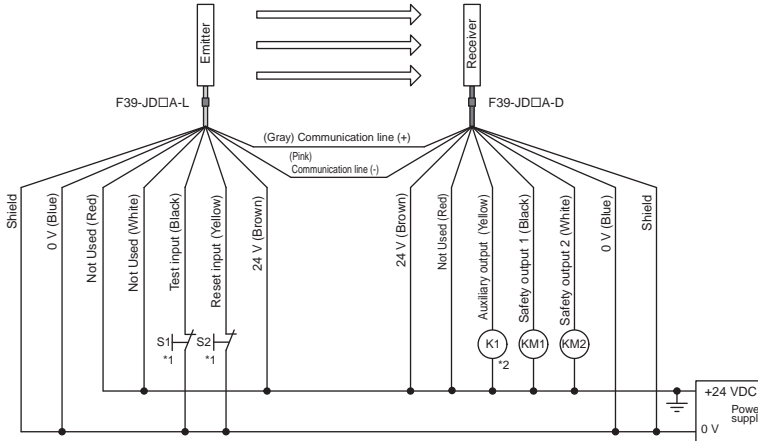

- S1 : External test switch (connect to 0 V if a switch is not required)
 S2 : Lockout reset switch (connect to 24 V if a switch is not required)
 KM1, KM2 : Safety relay with force-guided contact (G7SA) or magnetic contactor
 K1 : Load or PLC, etc. (for monitoring)

*1 Use a switch for micro loads (Input specifications: 24V, 1.0mA or less)
 *2 F3SJ can work even if K1 is not connected.



6. Mounting and Beam Alignment



For brackets other than top/bottom brackets (F39-LJB1) and intermediate brackets (F39-LJB2) as well as external dimensions and mounting, refer to *F3SJ-B-01T series user's manual*.

6-1. Mutual Interference Prevention

■ Series Connection

Up to three sets of F3SJ-B-01Ts can be series-connected. Series connection allows them to be used as a safety light curtain, requiring only one set to be wired to a controller and preventing mutual interference. If any one set of series-connected F3SJ-B-01T is blocked, both of the safety outputs turn OFF. The indication LED for each F3SJ-B-01T turns ON separately.

- Number of connections: Up to three sets
- Total number of beams: Up to 192 beams
- Connection cable length between two F3SJ-B-01Ts in series connection: 7 m max.

■ No Connection

Mutual interference is prevented in up to 3 sets, using interference light avoidance algorithm. If 4 or more sets of F3SJ-B-01T are installed and are not connected to each other, arrange them so that mutual interference does not occur. If 2 sets are installed near each other, reflection from the surface of the F3SJ-B-01T may cause mutual interference. When mutual interference occurs, the safety outputs are turned OFF in a moment or the F3SJ-B-01T enters lockout. Combining countermeasures 1 to 4 shown below is effective.

1. Install a physical barrier between 2 sets
2. Alternate the direction of emission between 2 sets (alternation) If 2 sets are installed near each other, reflection from the surfaces may cause mutual interference. For such a case, it can be improved by reducing operating range through the setting tool (see Step 3).
3. Reducing operating range (setting change by the setting tool is required)
4. Keep sufficient distance between the F3SJ-B-01Ts so that mutual interference does not occur

6-2. Distance from Reflective Surfaces

Install the sensor system at distance D or further from highly reflective surfaces such as metallic walls, floors, ceilings, or workpieces, as shown below.

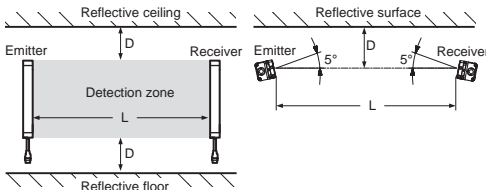

Distance between an emitter and a receiver (operating range L)	Allowable installation distance D
0.2 to 3 m	0.13 m
More than 3 m	$L/2 \times \tan 5^\circ = L \times 0.044$ (m)

6-3. Safety Distance

How to calculate the safety distance specified by International Standard ISO 13855(European standard EN ISO 13855)(Reference)

■ If a person approaches the detection zone of the F3SJ-B-01T perpendicularly

$$S = K \times T + C \dots \text{Formula (1)}$$

- S: Safety distance
 - K: Approach speed to the detection zone
 - T: Total response time of the machine and F3SJ-B-01T
 - C: Additional distance calculated by the detection capability of the F3SJ-B-01T
- <System that has detection capability of 30mm or less>

Use $K = 2,000\text{mm/s}$ and $C = 8 \times (d - 14\text{mm})$ in formula (1) for the calculation.

$$S = 2,000\text{mm/s} \times (T_m + T_s) + 8 \times (d - 14\text{mm})$$

- S = Safety distance (mm)
- T_m = Machine's response time (s)
- T_s = Response time of the F3SJ-B-01T from ON to OFF (s)
- d = Detection capability of the F3SJ-B-01T (mm)

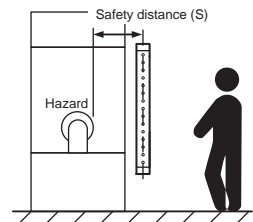

Please refer to the user's manual for calculation of following safety distance.

- Possible circumventing by reaching over the detection zone
- In case of horizontal approach of a human body to F3SJ-B-01T's detection zone
- How to calculate the safety distance specified by American standard ANSI B11.19(reference)



■ Dimensions (Check position)

[Side mounting]

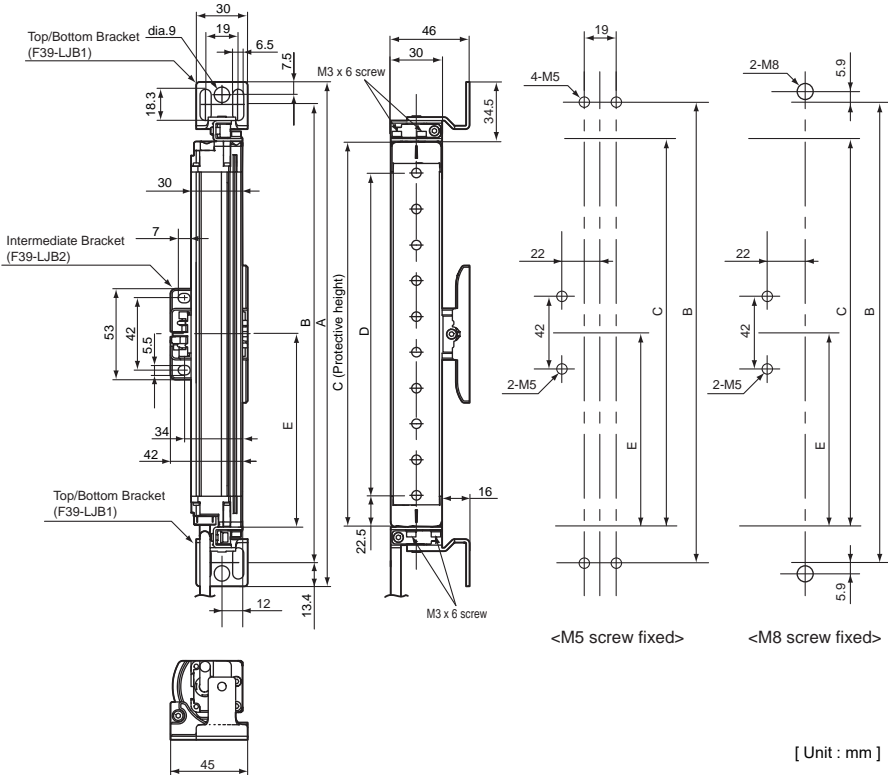

Step1
Check position
↓
Step2
Mount
↓
Step3
Align beams

Dimensions A to E

A	C+69
B	C+42.2
C	4-digit number of the type name (protective height)
D	C-45
E	Depends on the protective height. See the table below.

Dimensions E

Protective height	Number of Intermediate Brackets	Dimensions E
0185 to 1105	0	-
1185 to 1345	1	C/2 max.
1425 to 2065	2	C/3 max.

* Value E must be 700 mm or less when not using value E obtained from the calculation above.



If the protective height exceeds 1105mm, use the intermediate brackets as many as and on the positions specified in the dimensional drawing. Otherwise ratings/specifications cannot be satisfied.



If load is applied to the sensor unit in your environment, add intermediate bracket(s).



For mounting brackets other than top/bottom brackets and intermediate brackets (F39-LJB1/F39-LJB2) as well as external dimensions, refer to *F3SJ-B-01T series user's manual*.



6-5. Mounting and Beam Alignment



Mounting brackets are not included in the product. You must purchase them separately.

Step1

Check
position

Step2

Mount



Step3

Align
beams

1. Loosen the intermediate mounting bracket bolts.

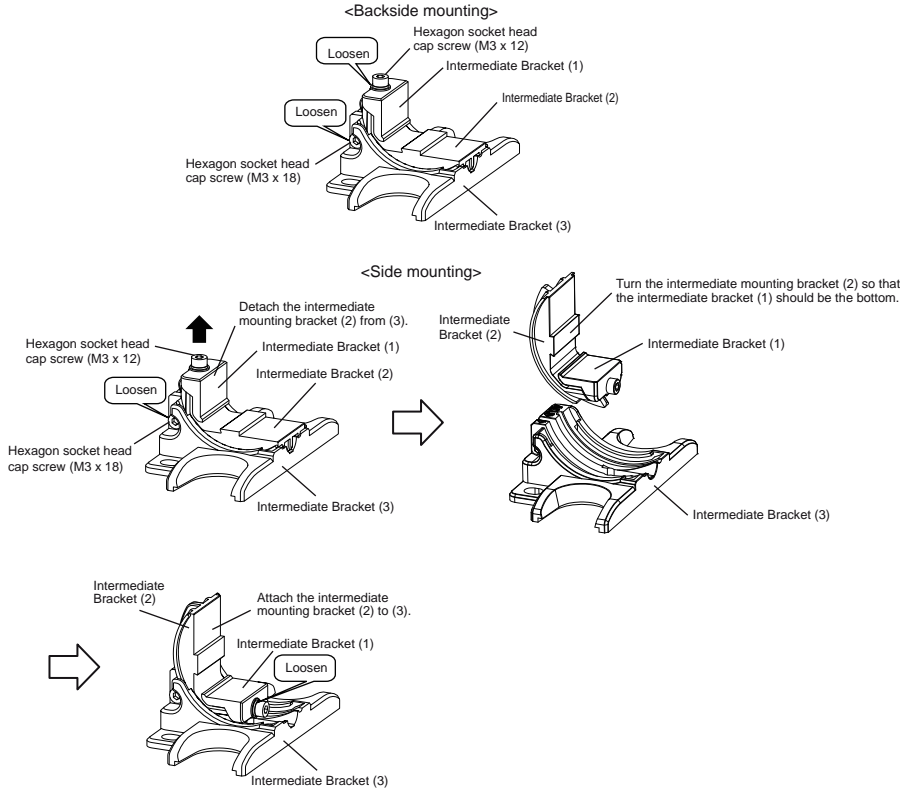

2. Lightly tighten the intermediate mounting bracket to the case.

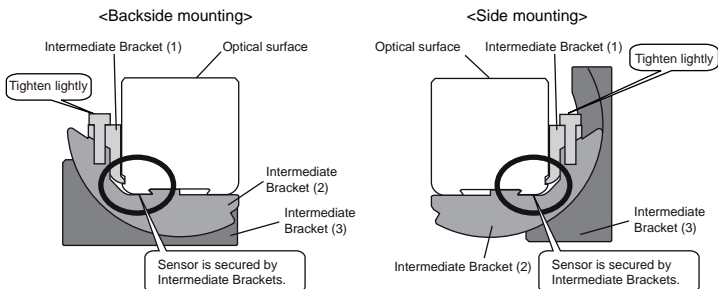

For position and number of intermediate mounting brackets, refer to 6-4 of this document.



3. Attach the top/bottom brackets to the case.

<Backside mounting>

Hexagon socket head cap screws (M3 x 6)
(Recommended tightening torque: 0.54Nm)

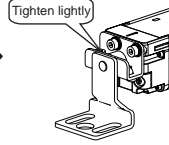
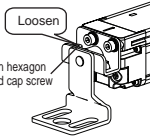
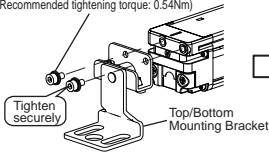

<Side mounting>

Hexagon socket head cap screws (M3 x 6)
(Recommended tightening torque: 0.54Nm)

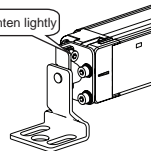
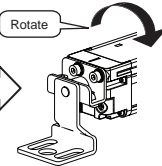
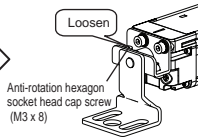
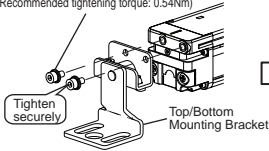

Step1

Check position



Step2

Mount



Step3

Align beams

4. Fix the unit on the wall.

<Backside mounting>

Hexagon socket head cap screw
(M3 x 12)
(Recommended tightening torque: 0.54Nm)

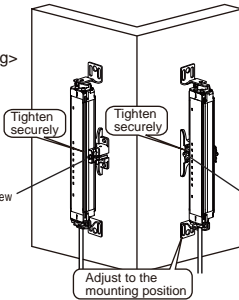

<Side mounting>

Hexagon socket head cap screw
(M3 x 12)
(Recommended tightening torque: 0.54Nm)

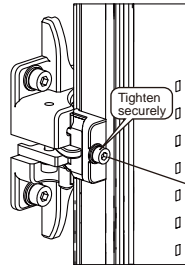

Hexagon socket head cap screw
(M3 x 12)
(Recommended tightening torque: 0.54Nm)

Wall-mounting screw (M5)

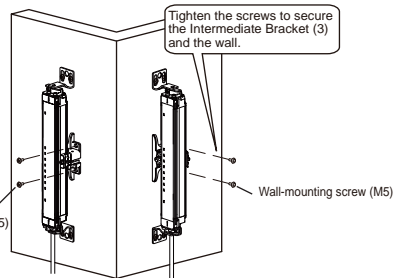
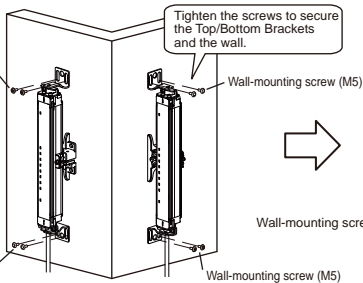

Wall-mounting screws are not included.

5. Align beams based on the indicators.

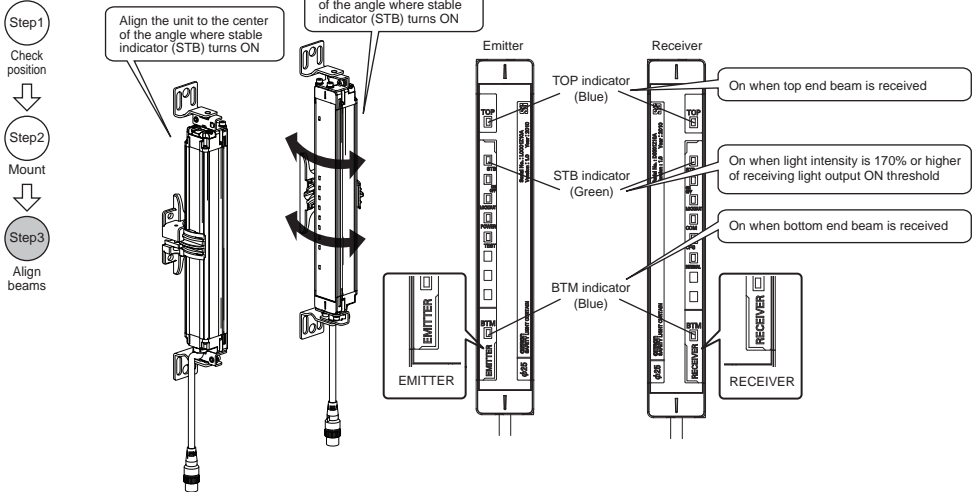

The angle adjustment range of intermediate mounting bracket (F39-LJB2) is +/-30 degrees.

6. Fully tighten the hexagon socket screws (M3 x 8/M3 x 18) of top/bottom brackets and intermediate brackets that were lightly tightened.

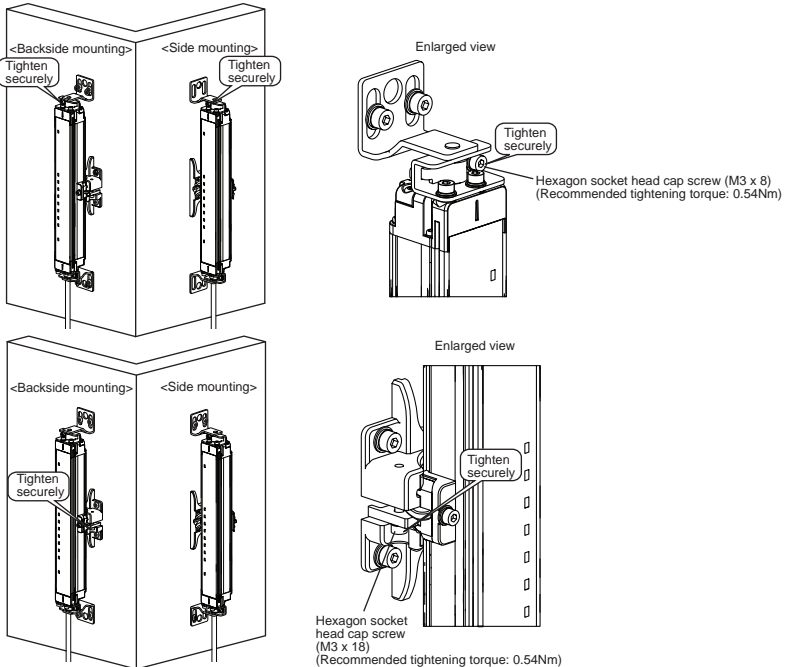

Please do not tighten each screw one by one. Fully tighten all of them in a balanced manner at all places.

Tightening with torque exceeding the recommended value too much may lead to a failure.



7. Pre-Operation Checklists / Maintenance Checklists

After wiring, mounting and beam alignment are done, check the operation of the F3SJ-B-01T.

Pre-Operation Checklists

After installation, the highest level administrator must use the following checklist to verify the operation, placing a check mark in each of the boxes.

■ Checklists

- Installation Condition Check

- The machine itself does not prevent the operation of safety functions such as stopping.
- The hazardous part of a machine cannot be reached without passing through the detection zone of the F3SJ-B-01T.
- The system is configured so that the F3SJ-B-01T can always detect a worker who is working in the hazardous zone.
- The interlock reset switch is installed in a location that provides a clear view of the entire hazardous zone and it cannot be activated from within the hazardous zone.
- Safety distance has been calculated. Calculated distance: $S = ()$ mm
- The actual distance is equal to or greater than the calculated distance. Actual distance = $()$ mm
- Reflective surfaces are not installed in prohibited zones.
- Not installed in a reflective configuration.
- Not used in flammable or explosive atmosphere.

- Wiring check before power is turned ON

- Sharing the power supply with other devices may cause the F3SJ-B-01T to be affected by noise or voltage drop. It is recommended that this safety component use a dedicated power supply but do not share with other devices.
- The power supply unit provides 24 VDC while complying with the EMC Directive, Low Voltage Directive, output holding specification.
- The power supply polarity is not connected in reverse.
- Emitter/receiver cables are properly connected to the respective emitters/receivers.
- Double insulation is provided between input/output and hazardous voltage (commercial power source, etc.).
- Outputs are not short-circuited to 0 V line.
- Loads are not connected to the 0 V line.
- All lines are not connected to commercial power source.
- Model of emitter and receiver must be the same.
- When two or more sets of F3SJ-B-01Ts are used, they are series-connected or mutual interference prevention measures are taken.
- When 2 or more sets of F3SJ-B-01T are used in series connection, they must not be connected to a sensor other than F3SJ-B-01T.
- A cap is attached to the secondary sensor that is located farthest from the power supply.
- Neither connector nor bracket must be loose.
- Auxiliary output must not be used as safety output.
- Power supply's +24 V must be grounded.
- Wiring must not be bent, cracked, nor damaged.

- Operation Check While the Machine Is Stopped

- The test rod is not deformed.

Depending on the unit's model and settings of floating blanking function, detection capability may vary. Use a test rod with an appropriate diameter for inspection. The model name of test rod is as follows.

Model name	Diameter
F39-TRD25	Dia. 25mm



- The sensor can detect a test rod wherever it is in the detection zone. In other words, when a test rod is inserted into the detection zone, the stable-state indicators (STB) turn off and the ON/OFF output-state indicators turn red.

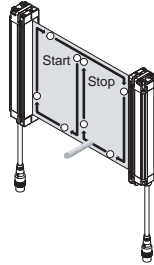

- When the external test function is used:
The ON/OFF-state indicator turns ON in red when the test input line is set to open or short-circuited to 1/2 Vs to Vs or open.

-Checking that Hazardous Parts Stop While the Machine Operates

- The hazardous parts stop immediately when a test rod is inserted into the detection zone at three positions: "directly in front of the emitter", "directly in front of the receiver", and "between the emitter and receiver". (Use the appropriate test rod.)
- The hazardous parts remain stopped as long as the test rod is in the detection zone.
- The hazardous parts stop when the power of the F3SJ-B-01T is turned OFF.
- The actual response time of the whole machine is equal to or less than the calculated value.

Maintenance Checklists

To ensure safety, keep a record of the inspection results. When the user is a different person from those who installed or designed the system, he/she must be properly trained for maintenance.

■Checklists

-Inspection at Startup and When Changing Operators

- There is no approach route other than through the detection zone of the F3SJ-B-01T.
- Part of the operator's body always remains in the detection zone of the F3SJ-B-01T when working around the machine's hazardous part.
- The actual safety distance is equal to or greater than the calculated value.
- There must be no dirt on or damage to the optical surface and spatter protection cover (F39-HB□□□□, sold separately) of the F3SJ-B-01T.
- The ON/OFF-state indicator turns ON in red when the test input line is set to open or short-circuited to 1/2 Vs to Vs or open.
- The test rod is not deformed.
- When the power of the F3SJ-B-01T is turned ON while nothing is in the detection zone, it must operate as follows:
The power indicator and ON/OFF-state indicators turn green within 2 seconds after the F3SJ-B-01T is turned ON.
- Nothing should exist in the detection zone and stable-state indicators must turn ON at power on.
- The test rod is detected when it is moved around in the detection zone as shown in the diagram of Pre-Operation Checklists.
In other words, when a test rod is inserted into the detection zone, the stable-state indicators (STB) turn off and the ON/OFF-state indicators turn red.
- Neither connector nor bracket must be loose.

-Checking that Hazardous Parts Stop While the Machine Operates

- The hazardous parts are movable when nothing is in the detection zone.
- The hazardous parts stop immediately when a test rod is inserted into the detection zone at three positions: "directly in front of the emitter", "directly in front of the receiver", and "between the emitter and receiver". (Use the appropriate test rod.)
- The hazardous parts remain stopped as long as the test rod is in the detection zone.



- The hazardous parts stop when the power of the F3SJ-B-01T is turned OFF while nothing is in the detection zone.

-Items to Inspect Every 6 Months or When Machine Settings Are Changed

In addition to inspection item at operation start, following items must also be verified.

- The outputs of the F3SJ-B-01T and the machine are properly wired.
- The total number of times that the control relays/contactors have switched is significantly lower than their design lives.
- There is no disturbance light.
- When an F3SJ-B-01T is connected again, the cap is attached to the secondary sensor that is located farthest from the power supply.
- Power supply's +24 V must be grounded.
- Wiring must not be bent, cracked, nor damaged.

Suitability for Use

Omron Companies shall not be responsible for conformity with any standards, codes or regulations which apply to the combination of the Product in the Buyer's application or use of the Product. At Buyer's request, Omron will provide applicable third party certification documents identifying ratings and limitations of use which apply to the Product. This information by itself is not sufficient for a complete determination of the suitability of the Product in combination with the end product, machine, system, or other application or use. Buyer shall be solely responsible for determining appropriateness of the particular Product with respect to Buyer's application, product or system. Buyer shall take application responsibility in all cases.

NEVER USE THE PRODUCT FOR AN APPLICATION INVOLVING SERIOUS RISK TO LIFE OR PROPERTY WITHOUT ENSURING THAT THE SYSTEM AS A WHOLE HAS BEEN DESIGNED TO ADDRESS THE RISKS, AND THAT THE OMRON PRODUCT(S) IS PROPERLY RATED AND INSTALLED FOR THE INTENDED USE WITHIN THE OVERALL EQUIPMENT OR SYSTEM.

See also Product catalog for Warranty and Limitation of Liability.

OMRON Corporation Industrial Automation Company (Manufacturer)

Shiokoji Horikawa, Shimogyo-ku, Kyoto, 600-8530 JAPAN

Contact: www.ia.omron.com

Regional Headquarters

■ OMRON EUROPE B.V. (Representative and Importer in EU)
Wegalaan 67-69, NL-2132 JD Hoofddorp
THE NETHERLANDS
Tel: (31)-2356-81-300 / FAX: (31)-2356-81-388

■ OMRON ASIA PACIFIC PTE. LTD.
No. 438A Alexandra Road # 05-05/08 (Lobby 2),
Alexandra Technopark,
Singapore 119967
Tel: (65) 6835-3011 / Fax: (65) 6835-2711

■ OMRON ELECTRONICS LLC
2895 Greenspoint Parkway, Suite 200
Hoffman Estates, IL 60169 U.S.A.
Tel: (1) 847-843-7900/Fax: (1) 847-843-7787

■ OMRON (CHINA) CO., LTD.
Room 2211, Bank of China Tower,
200 Yin Cheng Zhong Road,
PuDong New Area, Shanghai, 200120, China
Tel: (86) 21-5037-2222 / Fax: (86) 21-5037-2200

In the interest of product improvement, specifications are subject to change without notice.

セーフティライトカーテン F3SJ-B□□□□N25-01Tシリーズ

クイックインストールマニュアル



関連マニュアル	マニュアル番号
セーフティライトカーテン F3SJ-B-01T ユーザーズマニュアル	SCHG-735

はじめに

このたびはセーフティライトカーテン形 F3SJ-B □□□□ N25-01T シリーズ (以下 F3SJ-B-01T と呼びます) をお買い上げいただき、ありがとうございます。

本書は F3SJ-B-01T の配線から動作チェックまでの流れを示した簡易説明書です。



詳細については F3SJ-B-01T の取扱説明書、ユーザーズマニュアルを当社ウェブサイトからダウンロードし、よくお読みください。

<http://www.fa.omron.co.jp>

目次

1. 同梱物のご確認	1
2. 各部の名称	2
3. ライトカーテンセットアップの流れ	2
4. 機能選択フローチャート	2
5. 配線例	3
5-1. オートリセットモード、外部テスト使用	3
6. 取り付け・光軸調整	4
6-1. 上下金具 (形 F39-LJB1)、中間金具 (形 F39-LJB2) を取り付ける場合の外形寸法	4
6-2. 取り付け方法と光軸調整	6
7. 動作チェック	9
ご承諾事項 / お問い合わせ先	9

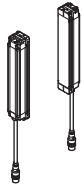
1. 同梱物のご確認

製品	数量、内容						
形F3SJ-B□□□□N25-01T本体 	投光器×1、受光器×1 各種機能設定 <table border="1"> <thead> <tr> <th>機能</th> <th>出荷時設定</th> </tr> </thead> <tbody> <tr> <td>外部テスト</td> <td>テスト入力線オープンもしくは、1/2Vs~Vs *1 印加時有効</td> </tr> <tr> <td>補助出力</td> <td>制御出力情報(出力反転機能：有効)</td> </tr> </tbody> </table> <p>*1ここでのVsとは使用環境での電圧値です。</p> <p> 詳細については F3SJ-B-01Tシリーズユーザーズマニュアルを参照してください。</p>	機能	出荷時設定	外部テスト	テスト入力線オープンもしくは、1/2Vs~Vs *1 印加時有効	補助出力	制御出力情報(出力反転機能：有効)
機能	出荷時設定						
外部テスト	テスト入力線オープンもしくは、1/2Vs~Vs *1 印加時有効						
補助出力	制御出力情報(出力反転機能：有効)						
取扱説明書	3						
クイックインストールマニュアル(本紙)	1						

 定格/性能、入出力回路、LED表示灯の点灯パターン、トラブルシューティングについては、F3SJ-B-01Tシリーズユーザーズマニュアルを参照してください。

2. 各部の名称

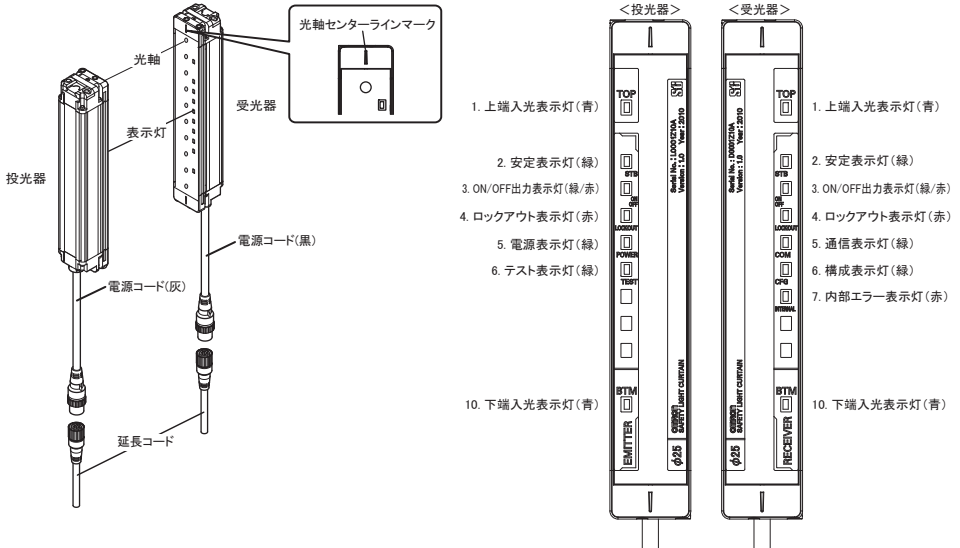

3. ライトカーテンセットアップの流れ

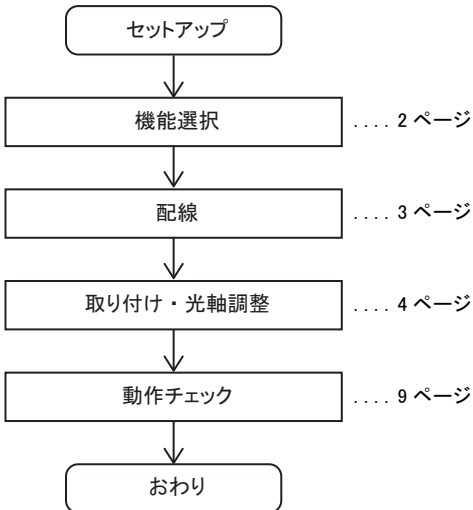

4. 機能選択フローチャート

使用する機能により配線が変わります。使用可能な機能は以下のとおりです。

- ・外部テスト機能
- ・補助出力機能

詳細については、F3SJ-B-01Tシリーズユーザーズマニュアルを参照下さい。



5. 配線例

 入出力回路および下記以外の配線例については、F3SJ-B-01Tシリーズユーザーズマニュアルを参照してください。

5-1. オートリセットモード、外部テスト使用

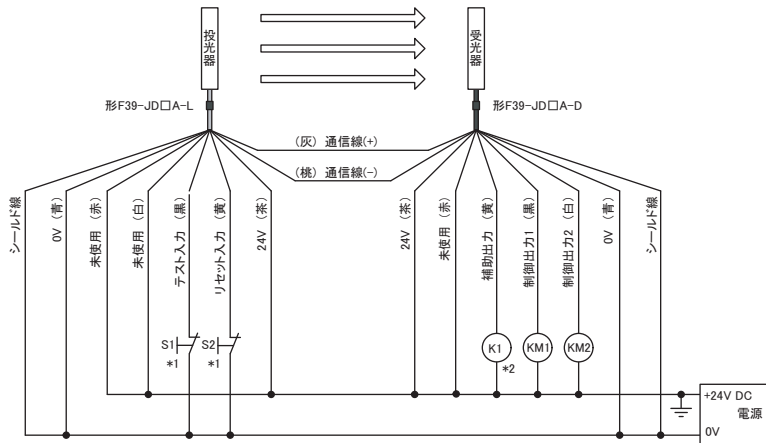

- S1 : 外部テストスイッチ (スイッチが不要な場合、0Vに接続)
 S2 : ロックアウトリセットスイッチ (スイッチが不要な場合、24Vに接続)
 KM1、KM2 : 強制ガイド接点付きセーフティリレー (形 G7SA) やマグネットコンタクト
 K1 : 負荷、PLC 等 (モニタ用)

*1 微小負荷用スイッチ(入力仕様：24V、1.0mA以下)をご使用ください。
 *2 K1が未接続でも形F3SJは動作します。



6. 取り付け・光軸調整

 上下金具(形F39-LJB1)、中間金具(形F39-LJB2)以外の金具、外形寸法および取り付け方法については、F3SJ-B-01Tシリーズユーザーズマニュアルを参照してください。

6-1. 上下金具(形 F39-LJB1)、中間金具(形 F39-LJB2)を取り付ける場合の外形寸法

■外形寸法図(取り付け位置確認)

[背面取り付け時]

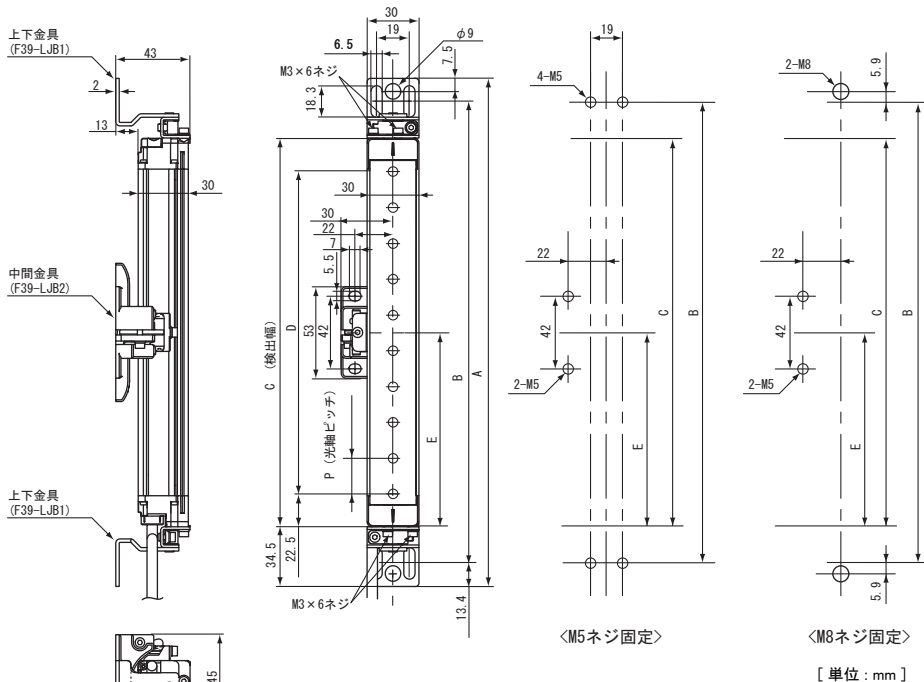

寸法A～E、Pについて

寸法A	C+69
寸法B	C+42.2
寸法C	形式中の4桁の数字(検出幅)
寸法D	C-45
寸法E	検出幅によって変わります。下表を確認ください。
寸法P	20

寸法Eについて

検出幅	中間金具の数	寸法E
0185～1105	0	-
1185～1345	1	C/2以下
1425～2065	2	C/3以下

* 上記計算により得られた値Eを使用しない場合Eは700mm以下とする。



検出幅が1105mmを超える場合、外形寸法図に記載されている規定の数量、位置にしたがって中間金具を使用してください。規定に満たない場合、定格/性能を満たすことができません。



センサ本体に荷重がかかるような使用をされる場合は、中間金具を追加してください。

Step1

取り付け位置確認



Step2

取り付け



Step3

光軸調整

■外形寸法図（取り付け位置確認）

[側面取り付け時]

- Step1
取り付け位置確認
- Step2
取り付け
- Step3
光軸調整

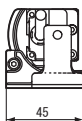
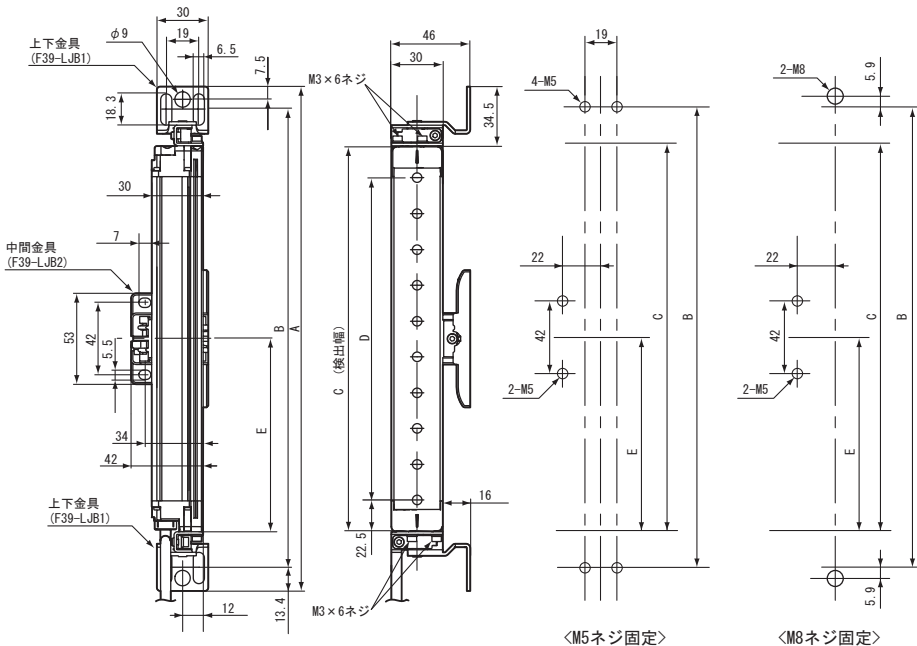

[単位: mm]

寸法A~Eについて

寸法A	C+69
寸法B	C+42.2
寸法C	形式中の4桁の数字（検出幅）
寸法D	C-45
寸法E	検出幅によって変わります。下表を確認ください。

寸法Eについて

検出幅	中間金具の数	寸法E
0185~1105	0	-
1185~1345	1	C/2以下
1425~2065	2	C/3以下

* 上記計算により得られた値Eを使用しない場合Eは700mm以下とする。

💡 検出幅が1105mmを超える場合、外形寸法図に記載されている規定の数量、位置にしたがって中間金具を使用してください。規定に満たない場合、定格/性能を満たすことができません。

💡 センサ本体に荷重がかかるような使用をされる場合は、中間金具を追加してください。

💡 上下金具、中間金具(形F39-LJB1、形F39-LJB2)以外の取付金具、外形寸法図については、F3S-J-B-01Tシリーズユーザーズマニュアルを参照してください。



6-2. 取り付け方法と光軸調整



取付金具は本体に付属していません。別途購入いただく必要があります。

1. 中間金具のボルトを緩めます。

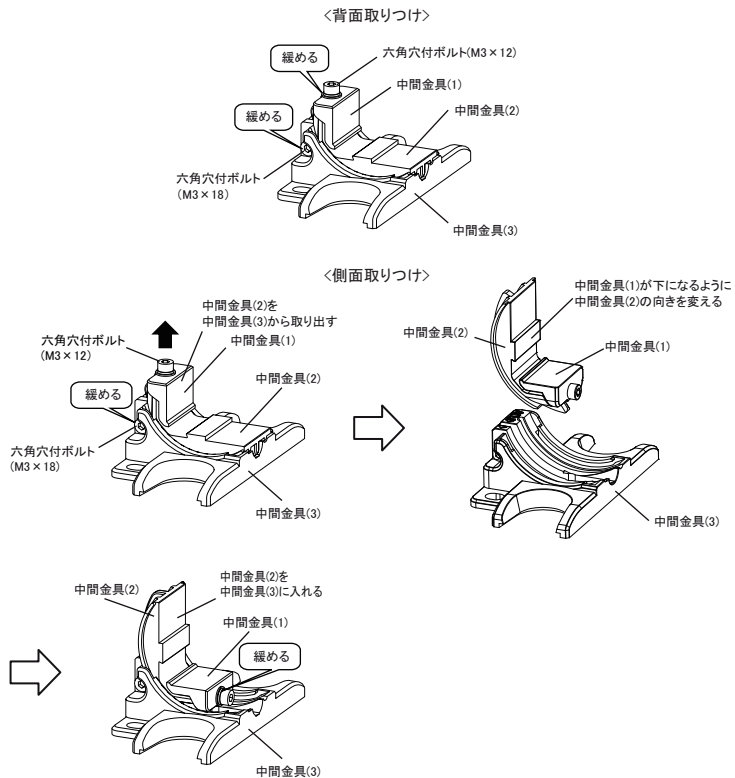

Step1

取り付け位置確認



Step2

取り付け



Step3

光軸調整

2. 中間金具をケースに仮締めします。

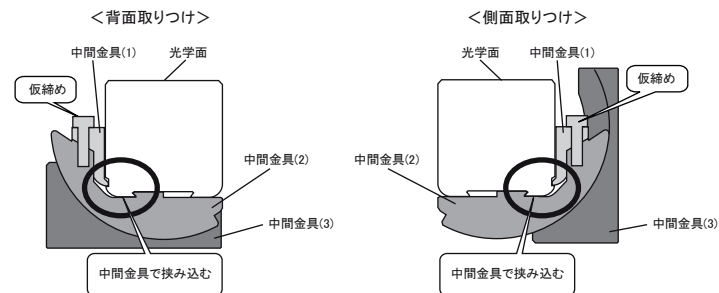

中間金具取り付け位置、個数については、本紙6-1項参照ください。

3. 上下金具をケースに取り付けます。

<背面取り付け>

Step1
取り付け
位置確認六角穴付ボルト(M3×6)
(推奨締め付けトルク:0.54Nm)本締め
上下金具

緩める

回転止め
六角穴付ボルト
(M3×8)

仮締め

Step2
取り付け

<側面取り付け>

Step3
光軸調整六角穴付ボルト(M3×6)
(推奨締め付けトルク:0.54Nm)本締め
上下金具

緩める

回転止め
六角穴付ボルト
(M3×8)

回転させる

仮締め

4. 壁面へ固定します。

<背面取り付け>

<側面取り付け>

本締め

本締め

六角穴付ボルト(M3×12)
(推奨締め付けトルク:0.54Nm)六角穴付ボルト(M3×12)
(推奨締め付けトルク:0.54Nm)

取り付け位置に合わせる

本締め

六角穴付ボルト(M3×12)
(推奨締め付けトルク:0.54Nm)

壁面取り付けネジ(M5)

上下金具と壁面の
ネジを本締める

壁面取り付けネジ(M5)

壁面取り付けネジ(M5)

壁面取り付けネジ(M5)

中間金具(3)と壁面の
ネジを本締める

壁面取り付けネジ(M5)

壁面取り付けネジ(M5)

💡 壁面との取り付けネジは付属していません。



5. 表示灯を参考に光軸調整を行います。

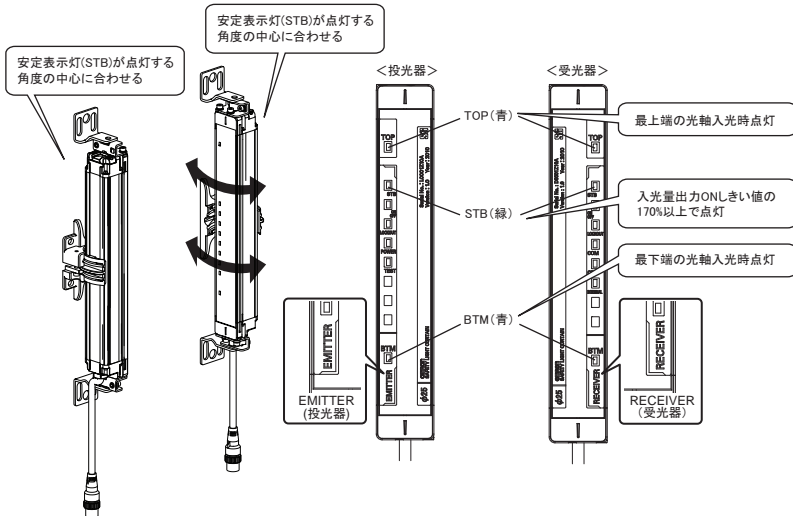

Step1

取り付け位置確認



Step2

取り付け



Step3

光軸調整



中間取付金具(形F39-LJB2)の角度調整範囲は±30°です。

6. 仮締めしていた上下金具、中間金具の回転止め六角穴付ボルト(M3×8、M3×18)を本締めします。

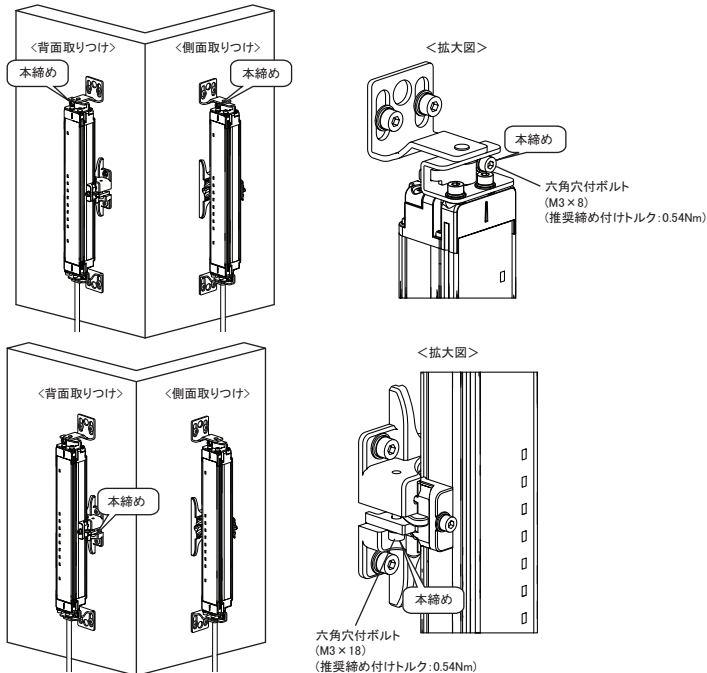

各ネジは1ヶ所ずつ締めるのではなく、全箇所バランスよく本締めしてください。



推奨値を大きく超えるトルクで固定すると故障の原因となります。



7. 動作チェック

配線、取り付け・光軸調整が終わったら、F3SJ-B-01Tの動作チェックを実施してください。



動作チェックはF3SJ-B-01Tシリーズユーザーズマニュアル記載のチェックリストに従い実施してください。



トラブルシューティングについては、F3SJ-B-01Tシリーズユーザーズマニュアルを参照してください。

ご承諾事項

当社商品は、一般工業製品向けの汎用品として設計製造されています。従いまして、次に掲げる用途での使用を意図しておらず、お客様が当社商品をこれらの用途に使用される際には、当社は当社商品に対して一切保証をいたしません。ただし、次に掲げる用途であっても当社の意図した特別な商品用途の場合や特別の合意がある場合は除きます。

- (a) 高い安全性が必要とされる用途（例：原子力制御設備、燃焼設備、航空・宇宙設備、鉄道設備、昇降設備、娯楽設備、医用機器、安全装置、その他生命・身体に危険が及びうる用途）
- (b) 高い信頼性が必要な用途（例：ガス・水道・電気等の供給システム、24時間連続運転システム、決済システムほか権利・財産を取扱う用途など）
- (c) 厳しい条件または環境での用途（例：屋外に設置する設備、化学的汚染を被る設備、電磁的妨害を被る設備、振動・衝撃を受ける設備など）
- (d) カタログ等に記載のない条件や環境での用途

* (a) から (d) に記載されている他、本カタログ等記載の商品は自動車（二輪車含む。以下同じ）向けではありません。自動車に搭載する用途には利用しないで下さい。自動車搭載用商品については当社営業担当者にご相談ください。

* 上記は適用用途の条件の一部です。当社のベスト、総合カタログ、データシート等最新版のカタログ、マニュアルに記載の保証・免責事項の内容をよく読んでご使用ください。

オムロン株式会社 インダストリアルオートメーションビジネスカンパニー

●製品に関するお問い合わせ先

お客様相談室

フリーダイヤル **0120-919-066**

携帯電話・PHS・IP電話などではご利用いただけませんので、下記の電話番号へおかけください。

電話 **055-982-5015** (通話料がかかります)

■営業時間：8:00～21:00 ■営業日：365日

●FAXやWebページでもお問い合わせいただけます。

FAX **055-982-5051** / www.fa.omron.co.jp

●その他のお問い合わせ

納期・価格・サンプル・仕様書は貴社のお取引先、または貴社担当オムロン販売員にご相談ください。オムロン制御機器販売店やオムロン販売拠点は、Webページでご案内しています。