



Machine Automation Controller NJ-series

# EtherCAT(R) Connection Guide

## OMRON Corporation

Vision Sensor  
(FQ-MS12[ ](-M)-ECT)

Network  
Connection  
Guide

### **About Intellectual Property Rights and Trademarks**

---

Microsoft product screen shots reprinted with permission from Microsoft Corporation.

Windows is a registered trademark of Microsoft Corporation in the USA and other countries.

EtherCAT(R) is registered trademark and patented technology, licensed by Beckhoff Automation GmbH, Germany.

Sysmac is a trademark or registered trademark of OMRON Corporation in Japan and other countries for OMRON factory automation products.

Company names and product names in this document are the trademarks or registered trademarks of their respective companies.

---

## Table of Contents

<b>1. Related Manuals</b> .....	<b>1</b>
<b>2. Terms and Definitions</b> .....	<b>2</b>
<b>3. Precautions</b> .....	<b>3</b>
<b>4. Overview</b> .....	<b>4</b>
<b>5. Applicable Devices and Device Configuration</b> .....	<b>4</b>
5.1. Applicable Devices .....	4
5.2. Device Configuration .....	5
<b>6. EtherCAT Settings</b> .....	<b>7</b>
6.1. Setting the Vision Sensor Parameters .....	7
6.2. Device Variables .....	8
<b>7. EtherCAT Connection Procedure</b> .....	<b>9</b>
7.1. Work Flow .....	9
7.2. Hardware Settings of the Vision Sensor .....	10
7.3. Setting Up the Controller .....	12
7.4. Setting the Vision Sensor Parameters .....	23
7.5. Checking the EtherCAT Communications .....	30
<b>8. Initialization Method</b> .....	<b>33</b>
8.1. Initializing the Controller .....	33
8.2. Initializing the Vision Sensor .....	33
<b>9. Revision History</b> .....	<b>34</b>

## 1. Related Manuals

The table below lists the manuals related to this document.

To ensure system safety, make sure to always read and heed the information provided in all Safety Precautions, Precautions for Safe Use, and Precaution for Correct Use of manuals for each device which is used in the system.

Cat.No.	Model	Manual name
W500	NJ501-□□□□ NJ301-□□□□	NJ-series CPU Unit Hardware User's Manual
W501	NJ501-□□□□ NJ301-□□□□	NJ-series CPU Unit Software User's Manual
W505	NJ501-□□□□ NJ301-□□□□	NJ-series CPU Unit Built-in EtherCAT(R) Port User's Manual
W504	SYSMAC-SE2□□□□	Sysmac Studio Version 1 Operation Manual
Z314	FQ-MS12□	Vision Sensor FQ-M-series Specialized Vision Sensor for Positioning User's Manual

## 2. Terms and Definitions

Term	Explanation and Definition
PDO Communications (Communications using Process Data Objects)	<p>This method is used for cyclic data exchange between the master unit and the slave units.</p> <p>PDO data (i.e., I/O data that is mapped to PDOs) that is allocated in advance is refreshed periodically each EtherCAT process data communications cycle (i.e., the period of primary periodic task).</p> <p>The NJ-series Machine Automation Controller uses the PDO Communications for commands to refresh I/O data in a fixed control period, including I/O data for EtherCAT Slave Units, and the position control data for the Servomotors.</p> <p>It is accessed from the NJ-series Machine Automation Controller in the following ways.</p> <ul style="list-style-type: none"> <li>· With device variables for EtherCAT slave I/O</li> <li>· With Axis Variables for Servo Drive and encoder input slave to which assigned as an axis</li> </ul>
SDO Communications (Communications using Service Data Objects)	<p>This method is used to read and write the specified slave unit data from the master unit when required.</p> <p>The NJ-series Machine Automation Controller uses SDO Communications for commands to read and write data, such as for parameter transfers, at specified times.</p> <p>The NJ-series Machine Automation Controller can read/write the specified slave data (parameters and error information, etc.) with the EC_CoESDORead (Read CoE SDO) instruction or the EC_CoESDOWrite (Write CoE SDO) instruction.</p>
Slave unit	<p>There are various types of slaves such as Servo Drives that handle position data and I/O terminals that handle the bit signals.</p> <p>The slave unit receives output data sent from the master, and sends input data to the master.</p>
Node address	<p>A node address is an address to identify a unit connected to EtherCAT.</p>

## 3. Precautions

- (1) Understand the specifications of devices which are used in the system. Allow some margin for ratings and performance. Provide safety measures, such as installing safety circuit in order to ensure safety and minimize risks of abnormal occurrence.
- (2) To ensure system safety, always read and heed the information provided in all Safety Precautions and Precautions for Safe Use of manuals for each device used in the system.
- (3) The user is encouraged to confirm the standards and regulations that the system must conform to.
- (4) It is prohibited to copy, to reproduce, and to distribute a part or the whole of this document without the permission of OMRON Corporation.
- (5) The information contained in this document is current as of July 2014. It is subject to change without notice for improvement.

The following notations are used in this document.

 <b>WARNING</b>	Indicates a potentially hazardous situation which, if not avoided, will result in minor or moderate injury, or may result in serious injury or death. Additionally there may be significant property damage.
---	--

 <b>Caution</b>	Indicates a potentially hazardous situation which, if not avoided, may result in minor or moderate injury or property damage.
--	---



### Precautions for Correct Use

Precautions on what to do and what not to do to ensure proper operation and performance.



### Additional Information

Additional information to read as required.

This information is provided to increase understanding or make operation easier.

### Symbol



The filled circle symbol indicates operations that you must do. The specific operation is shown in the circle and explained in text. This example shows a general precaution for something that must do.

## 4. Overview

This document describes the procedure for connecting Vision Sensor (FQ-MS12[](-M)-ECT, hereinafter referred to as Vision Sensor) of OMRON Corporation (hereinafter referred to as OMRON) to NJ-series Machine Automation Controller (hereinafter referred to as Controller) via EtherCAT and provides the procedure for checking their connection.

Refer to *Section 6 EtherCAT Settings* and *Section 7 EtherCAT Connection Procedure* to understand the setting method and key points to operate PDO Communications of EtherCAT.

## 5. Applicable Devices and Device Configuration

### 5.1. Applicable Devices

The applicable devices are as follows:

Manufacturer	Name	Model
OMRON	NJ-series CPU Unit	NJ501-[] [] [] [] NJ301-[] [] [] []
OMRON	Vision Sensor	FQ-MS12[]-ECT FQ-MS12[]-M-ECT



#### Precautions for Correct Use

As applicable devices above, the devices with the models and versions listed in *Section 5.2* are actually used in this document to describe the procedure for connecting devices and checking the connection.

You cannot use devices with versions lower than the versions listed in *Section 5.2*.

To use the above devices with versions not listed in *Section 5.2* or versions higher than those listed in *Section 5.2*, check the differences in the specifications by referring to the manuals before operating the devices.



#### Additional Information

This document describes the procedure to establish the network connection. It does not provide information on operation, installation or wiring method which is not related to the connection procedure. It also does not describe the functionality or operation of the devices. Refer to the manuals or contact your OMRON representative.

5.2. Device Configuration

The hardware components to reproduce the connection procedure of this document are as follows:

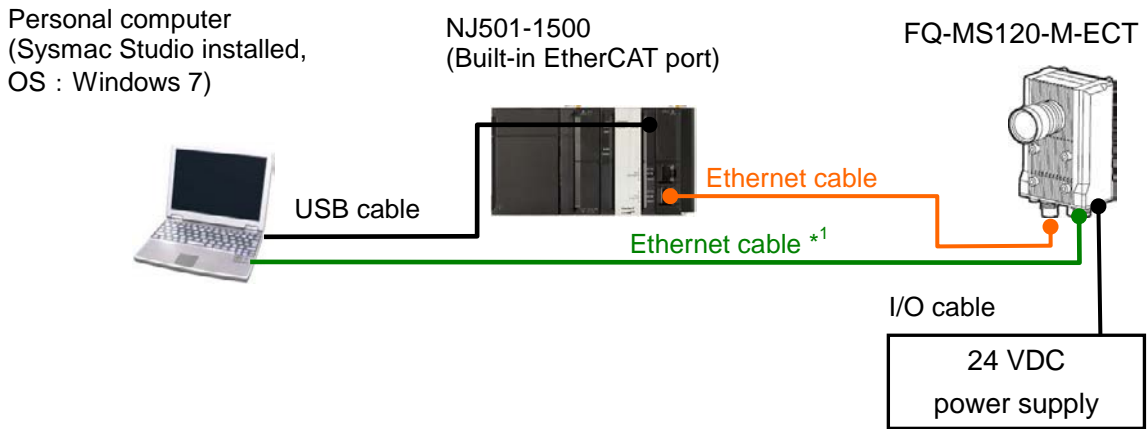

Manufacturer	Name	Model	Version
OMRON	CPU Unit (Built-in EtherCAT port)	NJ501-1500	Ver.1.08
OMRON	Power Supply Unit	NJ-PA3001	/
OMRON	Sysmac Studio <sup>*2</sup>	SYSMAC-SE2[ ][ ]	Ver.1.09
-	Personal computer (OS: Windows7)	-	/
-	USB cable (USB 2.0 type B connector)	-	/
OMRON	Ethernet cables (with industrial Ethernet connector(M12-RJ45)) <Two cables: for EtherCAT connection/ for connecting Personal computer to Vision Sensor>	FQ-WN[ ][ ] or, FQ-MWNL[ ][ ]	/
OMRON	Vision Sensor	FQ-MS120-M-ECT	Ver.1.5
OMRON	I/O cable	FQ-MWD[ ][ ] or, FQ- MWDL[ ][ ]	/
-	24 VDC power supply	-	/

<sup>\*1</sup>: Use the Sysmac Studio on the Personal computer to set up or adjust the Vision Sensor via Ethernet. You cannot set up or adjust the Vision Sensor through the Controller via EtherCAT.

<sup>\*2</sup>: In the *Vision Sensor FQ-M-series Specialized Vision Sensor for Positioning User's Manual* (Cat.No.Z314), Sysmac Studio is called "Sysmac Studio Standard Edition". This is to distinguish it from "Sysmac Studio Vision Edition" (SYSMAC-VE001L) that provides the selected functions that are required to set up the Vision Sensors from the Sysmac Studio.

Sysmac Studio Standard Edition (hereinafter referred to as Sysmac Studio) is used in this document.





### **Precautions for Correct Use**

---

The connection line of EtherCAT communication cannot be shared with other Ethernet networks.

Do not use devices for Ethernet such as a switching hub.

Use the cable (double shielding with aluminum tape and braiding) of Category 5 or higher, and use the shielded connector of Category 5 or higher.

Connect the cable shield to the connector hood at both ends of the cable.

---



### **Precautions for Correct Use**

---

Update the Sysmac Studio to the version specified in this section or higher version using the auto update function.

If a version not specified in this section is used, the procedures described in *Section 7* and subsequent sections may not be applicable. In that case, use the equivalent procedures described in the *Sysmac Studio Version 1 Operation Manual (Cat.No.W504)*.

---



### **Additional Information**

---

For specifications of the Ethernet cables and network wirings, refer to *Section 4 EtherCAT Network Wiring* of the *NJ-series CPU Unit Built-in EtherCAT(R) Port User's Manual (Cat.No.W505)*.

---



### **Additional Information**

---

The system configuration in this document uses USB for the connection to the Controller. For how to install a USB driver, refer to *A-1 Driver Installation for Direct USB Cable Connection* of the *Sysmac Studio Version 1 Operation Manual (Cat.No.W504)*.

---

## 6. EtherCAT Settings

This section describes the specifications such as parameters and device variables for the Vision Sensor that are set in this document.

Hereinafter, the Vision Sensor is referred to as the "Destination Device" or the "Slave Unit" in some descriptions.

### 6.1. Setting the Vision Sensor Parameters

The parameter required connecting the Controller and the Vision Sensor via EtherCAT is given below.

Setting item	Set value
Node address setting switch	1
Output data size	259 <sup>th</sup> +262 <sup>th</sup> sending PDO mapping: 256 bytes

## 6.2. Device Variables

The PDO communications data for the Destination Device are allocated to the Controller's device variables. The device variables and the data types are shown below.

### ■ Output area (from Controller to Destination Device)

Global variable	Data type	Meaning
E001_Vision_Control_Flag	DWORD	Control signal
E001_EXE	BOOL	Command execution
E001_TRIG	BOOL	Measurement trigger
E001_ERCLR	BOOL	Clear error
E001_DSA	BOOL	Data output request
E001_Vision_Command	DWORD	Command code
E001_Vision_Command_Parameter1	UDINT	Command parameter 1
E001_Vision_Command_Parameter2	UDINT	Command parameter 2
E001_Vision_Command_Parameter3	DINT	Command parameter 3

### ■ Input area (from Destination Device to Controller)

Global variable	Data type	Meaning
E001_Vision_Status_Flag	DWORD	Status signal
E001_FLG	BOOL	Command completed
E001_BUSY	BOOL	Processing in progress
E001_READY	BOOL	TRIG signal input available
E001_OR	BOOL	Overall judgement output
E001_RUN	BOOL	Run mode
E001_ERR	BOOL	Error signal
E001_GATE	BOOL	Data output completed
E001_Vision_Response	DWORD	Command code echo back
E001_Vision_Response_Code	DWORD	Response code
E001_Vision_Response_Data1	DINT	Response data
E001_Vision_Extended_Data	DINT	Extended data
E001_Vision_Data_Output1	DINT	Output data 1
E001_Vision_Data_Output2	DINT	Output data 2
E001_Vision_Data_Output3	DINT	Output data 3
:	:	:
E001_Vision_Data_Output63	DINT	Output data 63
E001_Vision_Data_Output64	DINT	Output data 64

### ■ Details of the status allocation (from Destination Device to Controller)

Global variable	Data type	Destination device data
E001_Sysmac_Error_Status	BYTE	Sysmac error status
E001_Observation	BOOL	Observation error information
E001_Minor_Fault	BOOL	Minor fault level error information

## 7. EtherCAT Connection Procedure

This section describes the procedure for connecting the Controller to the Vision Sensor via EtherCAT.

This document explains the procedures for setting up the Controller and the Vision Sensor from the factory default setting. For the initialization, refer to *Section 8. Initialization Method*.

### 7.1. Work Flow

Take the following steps to perform PDO Communications of EtherCAT.

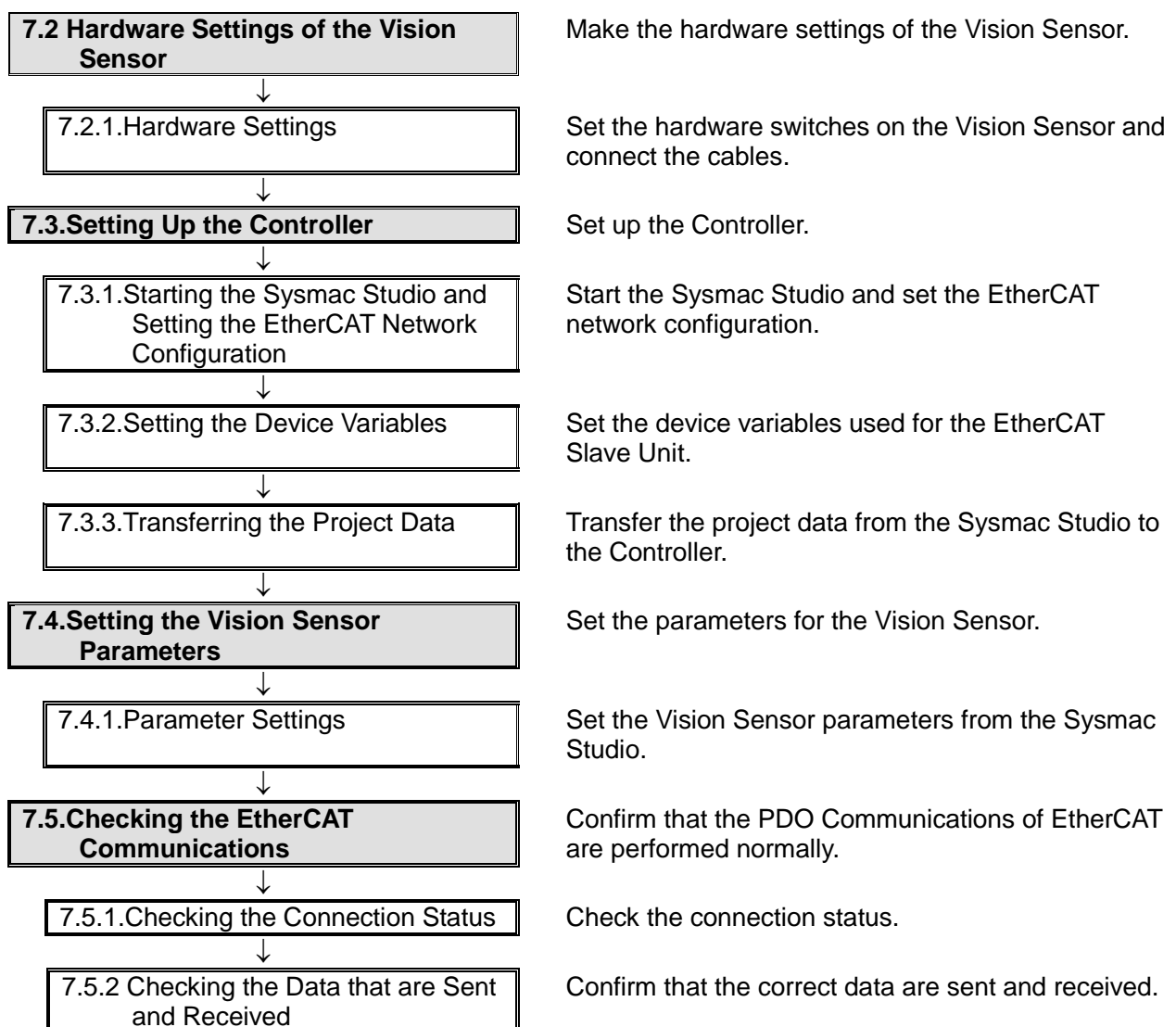

## 7.2. Hardware Settings of the Vision Sensor

Make the hardware settings of the Vision Sensor.

### 7.2.1. Hardware Settings

Set the hardware switches on the Vision Sensor and connect the cables.



#### Precautions for Correct Use

Make sure that the power supply is OFF when you perform the setting up.

- 1 Make sure that the power supply to the Vision Sensor is OFF.

\*If the power supply is turned ON, settings may not be applicable as described in the following procedures.

- 2 Check the position of the hardware switches and the connectors on the Vision Sensor by referring to the right figure.

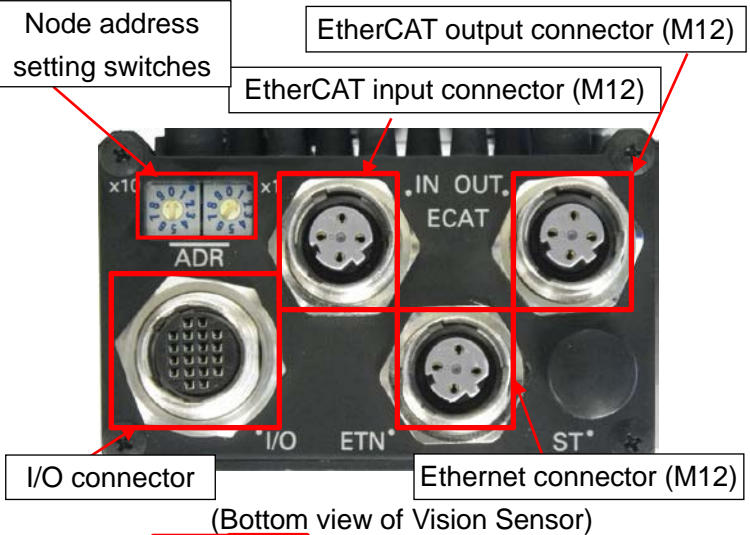

- 3 Set the Node address setting switches as follows:  
 x10: 0  
 x1: 1



- 4 Connect the Controller to the EtherCAT input connector with an Ethernet cable.  
 Connect the Personal computer to the Ethernet connector with an Ethernet cable.  
 Connect the 24 VDC power supply to the I/O connector with an I/O cable.

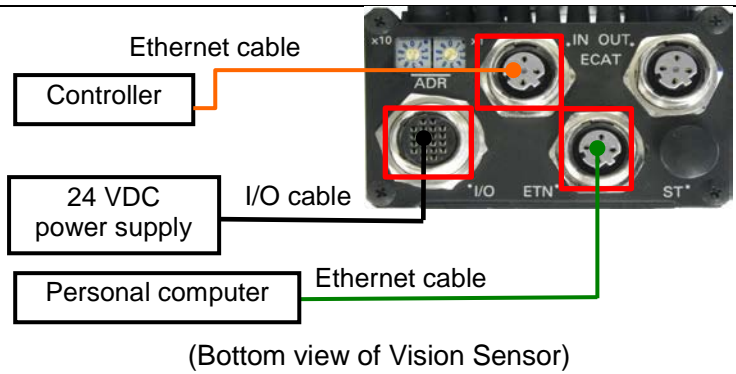

Connect power supply (24 V) to the brown I/O cable (24V), and GND to the blue I/O cable (GND).

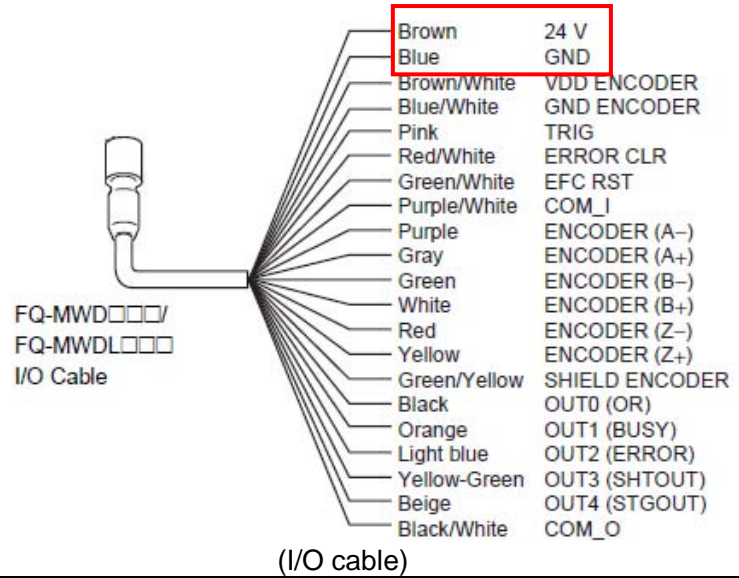

**Additional Information**

For details on wiring I/O cables, refer to *2-4 Wiring of the Vision Sensor FQ-M-series Specialized Vision Sensor for Positioning User's Manual (Cat.No.Z314)*.

- 5 Turn ON the Personal computer and 24 VDC power supply.



### 7.3. Setting Up the Controller

Set up the Controller.

#### 7.3.1. Starting the Sysmac Studio and Setting the EtherCAT Network Configuration

Start the Sysmac Studio and set the EtherCAT network configuration.

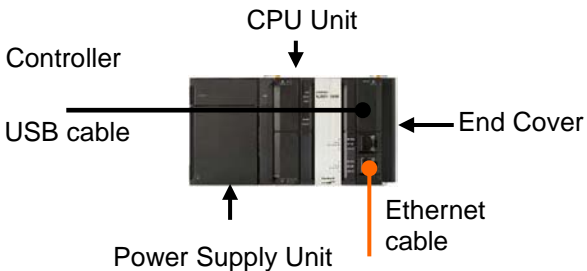
Install the Sysmac Studio and USB driver in the Personal computer beforehand.

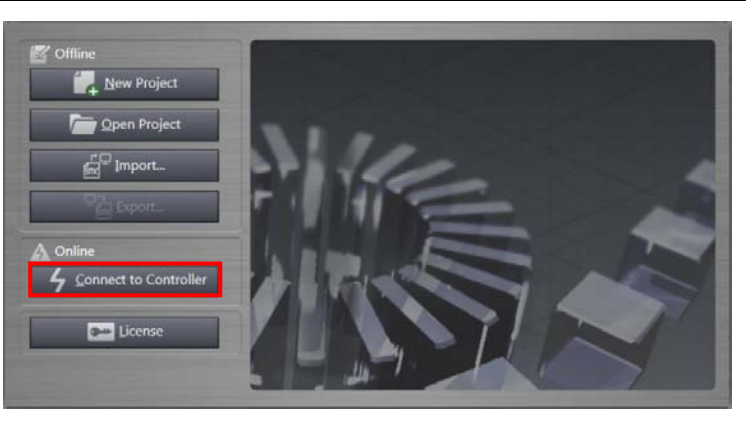
<p>1</p>	<p>Connect the Ethernet cable to the built-in EtherCAT port (PORT2) of the Controller and connect the USB cable to the peripheral (USB) port. As shown in 5.2. <i>Device Configuration</i>, connect the Personal computer, Vision Sensor, and Controller.</p>	 <p>The diagram shows a controller unit with several components labeled: 'CPU Unit' at the top, 'USB cable' on the left side, 'Power Supply Unit' at the bottom, 'End Cover' on the right side, and 'Ethernet cable' on the right side connected to a port.</p>
<p>2</p>	<p>Turn ON the power supply to the Controller.</p>	
<p>3</p>	<p>Start the Sysmac Studio.</p> <p>*If a confirmation dialog for an access right is displayed at start, execute a selection to start.</p>	 <p>The Sysmac Studio logo is a blue square with a white icon of a gear and a document, with the text 'Sysmac Studio' below it.</p>
<p>4</p>	<p>Click the <b>Connect to Controller</b> Button.</p>	 <p>The screenshot shows the Sysmac Studio interface with a menu on the left. The 'Connect to Controller' button, which has a lightning bolt icon, is highlighted with a red rectangle. Other buttons include 'New Project', 'Open Project', 'Import...', 'Export...', and 'License'. The background shows a 3D model of a robotic arm.</p>

- 5 The Connect to Controller Dialog Box is displayed. Select the *Direct connection via USB* Option of Connection type. Uncheck both the *Upload the project* Check Box and the *Display the Troubleshooting Dialog Box* Check Box of Operation after Connection.



Click the **Connect** Button.

- 6 Check the contents and click the **OK** Button if a confirmation dialog box on the right is displayed.

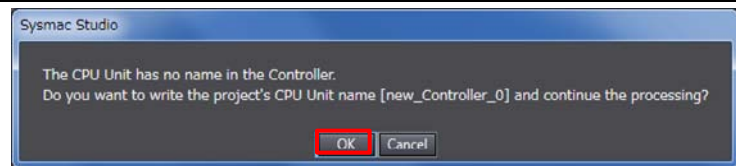

\*The displayed dialog depends on the status of the Controller used. Check the contents and click the **OK** or **Yes** Button to proceed with the processing.

- 7 A dialog box on the right is displayed. Check the contents and click the **OK** Button.

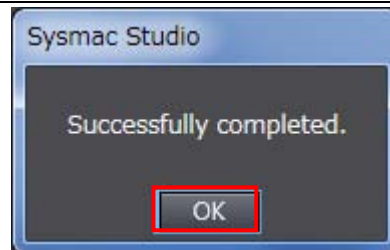



8 The Auto Connect Project Dialog Box is displayed online. When an online connection is established, a yellow bar is displayed on the top of the Edit Pane.

This window consists of the following panes.

- Left : Multiview Explorer
- Top right : Toolbox
- Bottom right:

  - Status Monitor Pane

- Middle top: Edit Pane

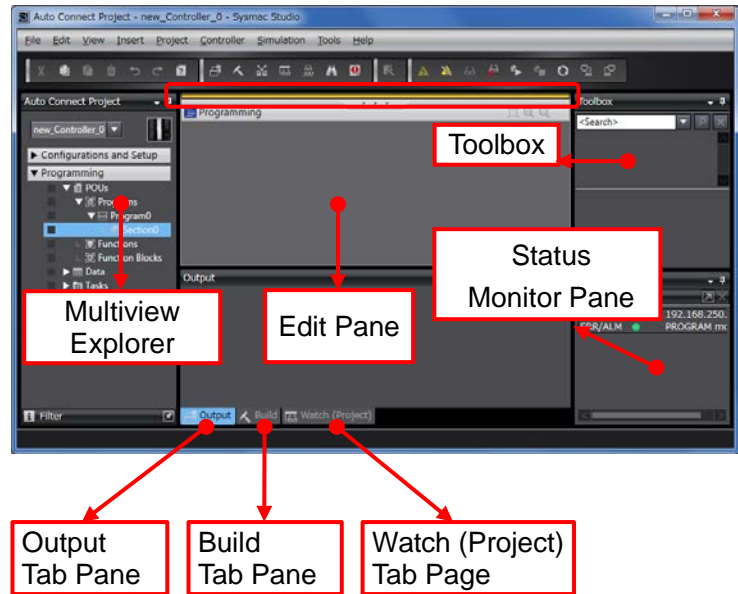

The following tab pages are displayed at the middle bottom of the window.

- Output Tab Page
- Build Tab Page
- Watch (Project) Tab Page



**Additional Information**

For details on online connections to a Controller, refer to *Section 5 Online Connections to a Controller* of the *Sysmac Studio Version 1 Operation Manual* (Cat.No.W504).

9 Double-click **EtherCAT** under **Configurations and Setup** in the Multiview Explorer.

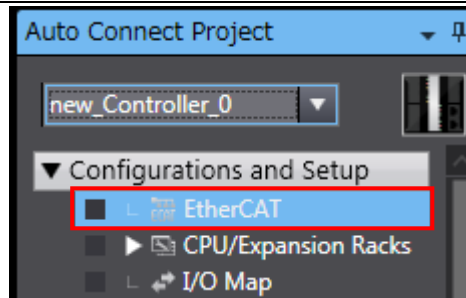

10 The EtherCAT Tab Page is displayed in the Edit Pane.

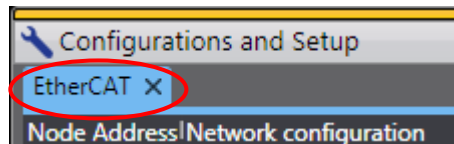

- 11 Right-click **Master** and select **Compare and Merge with Actual Network Configuration**.

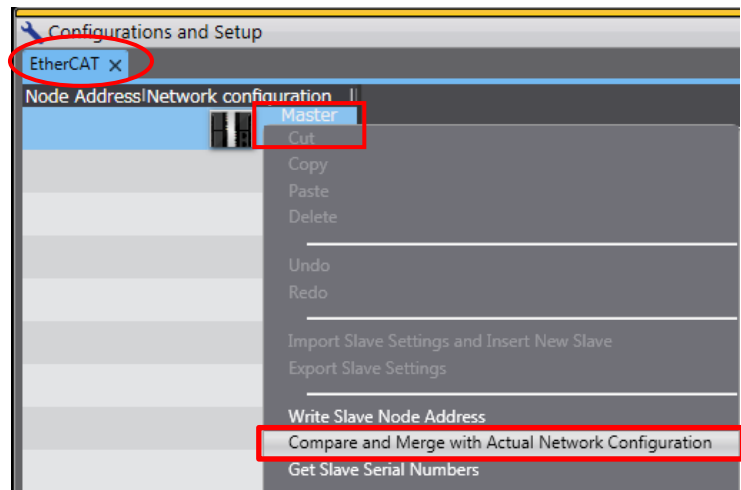

A screen is displayed stating "Get information is being executed".

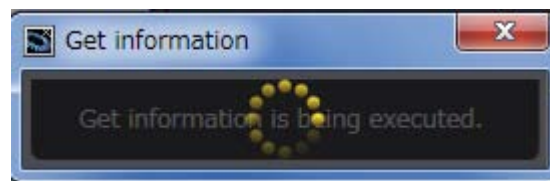

- 12 The Compare and Merge with Actual Network Configuration Dialog Box is displayed. Node address 1 and FQ-MS12x-M-ECT Rev:1.0 are added to the Actual network configuration after the comparison.

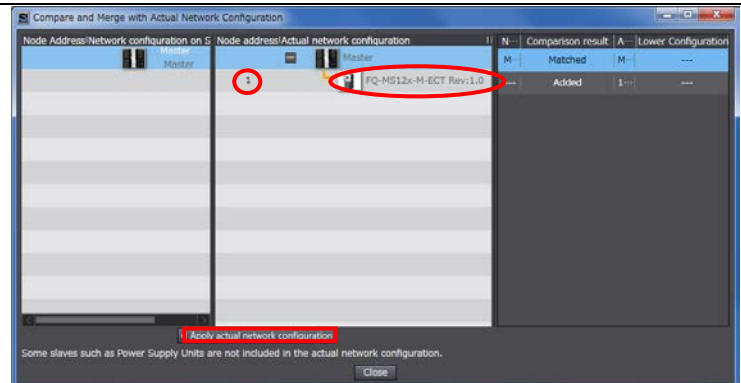

Click the **Apply actual network configuration** Button.

- 13 A confirmation dialog box is displayed. Check the contents and click the **Apply** Button.

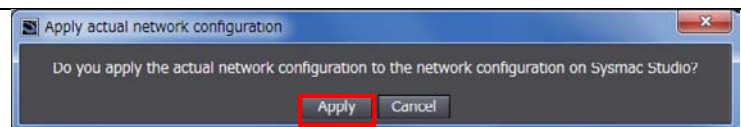

The dialog box on the right is displayed. Click the **Close** Button.

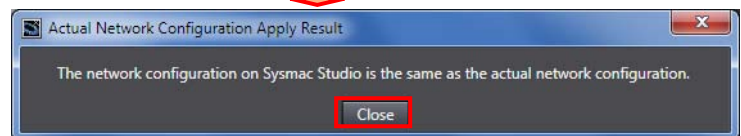

- 14 Node address 1, E001, and FQ-MS12x-M-ECT Rev:1.0 are added to the Network configuration on Sysmac Studio.

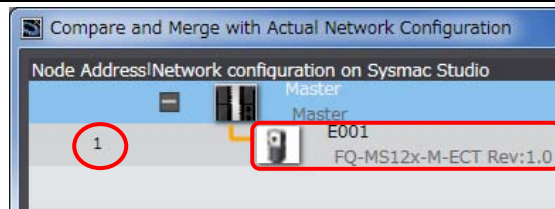

Confirm that the data above are added and click the **Close** Button.

Close

- 15 Node address 1, E001, and FQ-MS12x-M-ECT Rev:1.0 are added to the EtherCAT Tab Page on the Edit Pane.

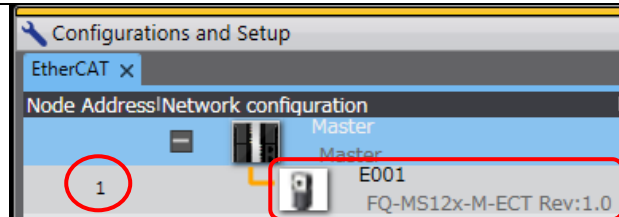

7.3.2. Setting the Device Variables

Set the device variables used for the EtherCAT Slave Unit.

- 1 Select **Offline** from the Controller Menu.

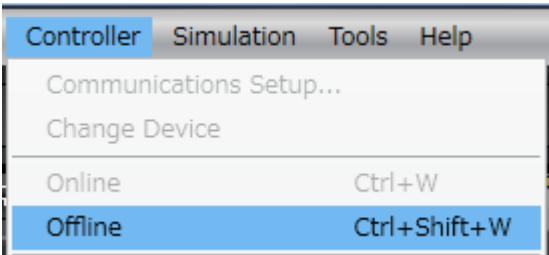

The yellow bar on the top of the Edit Pane disappears.

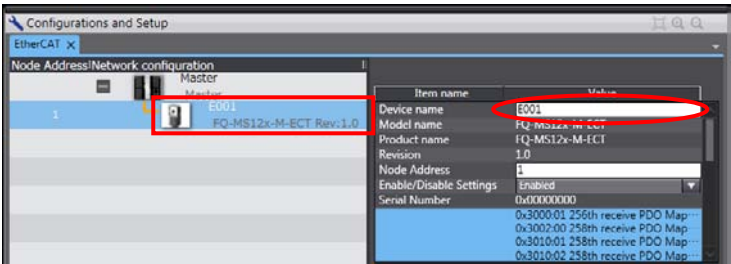

- 2 Select **FQ-MS12x-M-ECT Rev:1.0** in the EtherCAT Tab Page.  
Confirm that the Device name is E001.

\*Device name can be changed as desired.

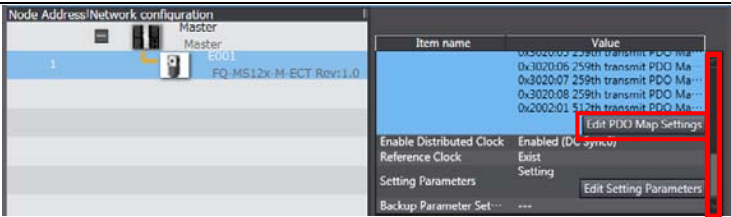

- 3 Click the **Edit PDO Map Settings** Button.

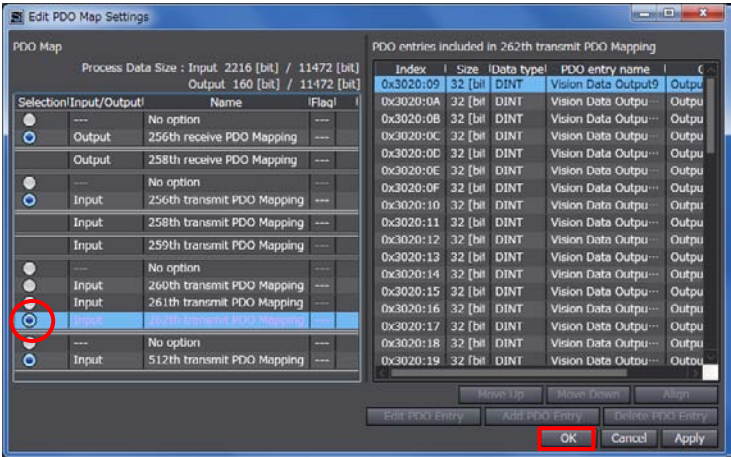
\*If the Edit PDO Map Settings Button is not displayed, scroll the pane by using the scroll bar until it appears.

- 4 The Edit PDO Map Settings Window is displayed. Select **Input 262th transmit PDO Mapping** and click the **OK** Button.

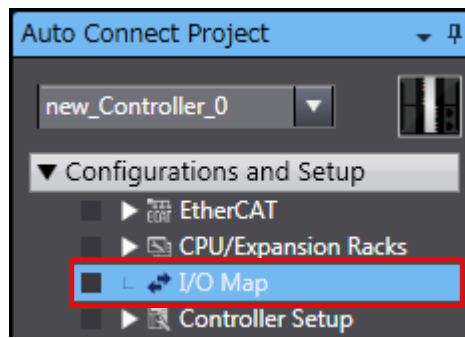

- 5 Double-click **I/O Map** under **Configurations and Setup** in the Multiview Explorer.



- 6 The I/O Map Tab Page is displayed on the Edit Pane. Confirm that Node1 is displayed in the *Position* Column and the Slave Unit is displayed.

Position	Port	Description	I/W	Data Type	Variable	Variable Comment	Variable Type
Node1	IP-MES12x-M-ECT	Control Flag	W	DWORD			
	EXE	Command execution	W	BOOL			
	TRIG	Measurement trigger	W	BOOL			
	ERCLR	Error clearing	W	BOOL			
	DSA	Data output request	W	BOOL			
	Vision Command	Command code	W	DWORD			
	Vision Command Parameter1	Command parameter1	W	UDINT			
	Vision Command Parameter2	Command parameter2	W	UDINT			
	Vision Command Parameter3	Command parameter3	W	DINT			
	Vision Status Flag	Status Flag	R	DWORD			
	FLG	Command execution comp	R	BOOL			
	BSY	Processing in progress	R	BOOL			
	READY	Possible state of TRIG input	R	BOOL			
	OR	Overall judgement output	R	BOOL			
	RUN	RUN Window	R	BOOL			
	ERR	Error signal	R	BOOL			
	GATE	Data output completion	R	BOOL			
	Vision Response	Echo back of command code	R	DWORD			
	Vision Response Code	Response code	R	DWORD			
	Vision Response Data1	Response data	R	DINT			
	Vision Extended Data	Extended data	R	DINT			
	Vision Data Output1	Output data 1	R	DINT			
	Vision Data Output2	Output data 2	R	DINT			
	Vision Data Output3	Output data 3	R	DINT			
	Vision Data Output4	Output data 4	R	DINT			
	Vision Data Output5	Output data 5	R	DINT			
	Vision Data Output6	Output data 6	R	DINT			

\*To manually set a variable name for the Slave Unit, click a column under the *Variable* Column and enter a name.

- 7 Right-click **Node1** and select **Create Device Variable**.

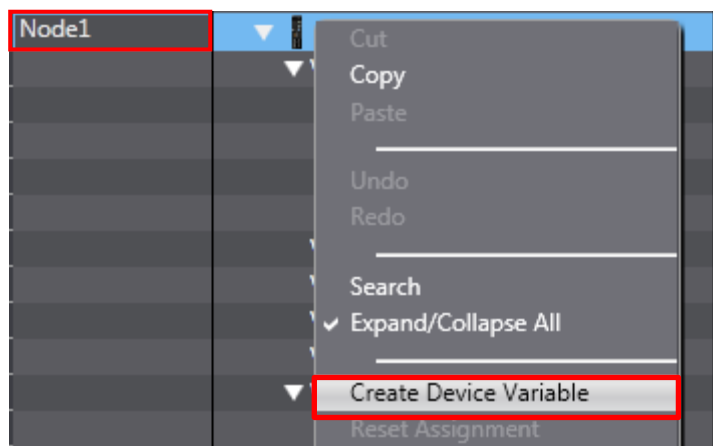

- 8 The variable names and variable types are automatically set.

Position	Port	Description	I/W	Data Type	Variable	Variable Comment	Variable Type
Node1	IP-MES12x-M-ECT	Control Flag	W	DWORD	001_Vision_Control_Flag		Global Variables
	EXE	Command execution	W	BOOL	001_EXE		Global Variables
	TRIG	Measurement trigger	W	BOOL	001_TRIG		Global Variables
	ERCLR	Error clearing	W	BOOL	001_ERCLR		Global Variables
	DSA	Data output request	W	BOOL	001_DSA		Global Variables
	Vision Command	Command code	W	DWORD	001_Vision_Command		Global Variables
	Vision Command Parameter1	Command parameter1	W	UDINT	001_Vision_Command_Parameter1		Global Variables
	Vision Command Parameter2	Command parameter2	W	UDINT	001_Vision_Command_Parameter2		Global Variables
	Vision Command Parameter3	Command parameter3	W	DINT	001_Vision_Command_Parameter3		Global Variables
	Vision Status Flag	Status Flag	R	DWORD	001_Vision_Status_Flag		Global Variables
	FLG	Command execution comp	R	BOOL	001_FLG		Global Variables
	BSY	Processing in progress	R	BOOL	001_BSY		Global Variables
	READY	Possible state of TRIG input	R	BOOL	001_READY		Global Variables
	OR	Overall judgement output	R	BOOL	001_OR		Global Variables
	RUN	RUN Window	R	BOOL	001_RUN		Global Variables
	ERR	Error signal	R	BOOL	001_ERR		Global Variables
	GATE	Data output completion	R	BOOL	001_GATE		Global Variables
	Vision Response	Echo back of command code	R	DWORD	001_Vision_Response		Global Variables
	Vision Response Code	Response code	R	DWORD	001_Vision_Response_Code		Global Variables
	Vision Response Data1	Response data	R	DINT	001_Vision_Response_Data1		Global Variables
	Vision Extended Data	Extended data	R	DINT	001_Vision_Extended_Data		Global Variables
	Vision Data Output1	Output data 1	R	DINT	001_Vision_Data_Output1		Global Variables
	Vision Data Output2	Output data 2	R	DINT	001_Vision_Data_Output2		Global Variables
	Vision Data Output3	Output data 3	R	DINT	001_Vision_Data_Output3		Global Variables
	Vision Data Output4	Output data 4	R	DINT	001_Vision_Data_Output4		Global Variables
	Vision Data Output5	Output data 5	R	DINT	001_Vision_Data_Output5		Global Variables
	Vision Data Output6	Output data 6	R	DINT	001_Vision_Data_Output6		Global Variables



### **Additional Information**

---

The device variables are named automatically from a combination of the device names and the port names.

The default device names are "E" followed by a serial number that starts from 001.

---



### **Additional Information**

---

In this document, device variables are automatically named for a unit (a slave).

Device variables can also be manually named for ports.

---

### 7.3.3. Transferring the Project Data

Transfer the project data from the Sysmac Studio to the Controller.

## ⚠ WARNING

Always confirm safety at the Destination Device before you transfer a user program, configuration data, setup data, device variables, or values in memory used for CJ-series Units from the Sysmac Studio.

The devices or machines may perform unexpected operation regardless of the operating mode of the CPU Unit.



## ⚠ Caution

After you transfer the user program, the CPU Unit restarts and communications with the EtherCAT slaves are cut off. During that period, the slave outputs behave according to the slave settings. The time that communications are cut off depends on the EtherCAT network configuration.

Before you transfer the user program, confirm that it will not adversely affect the device.

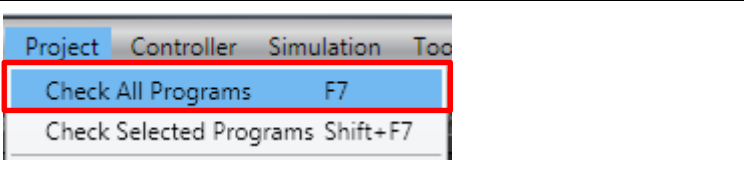
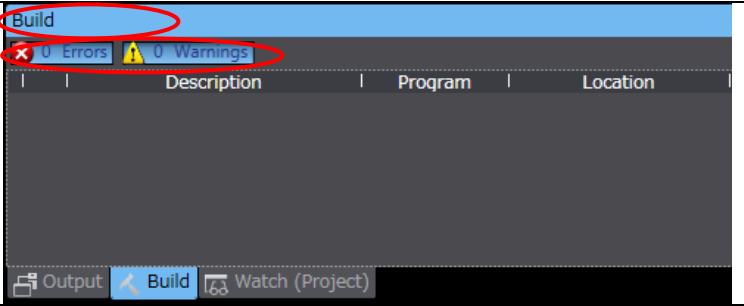
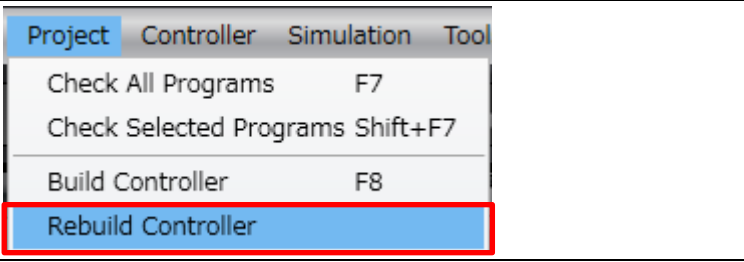
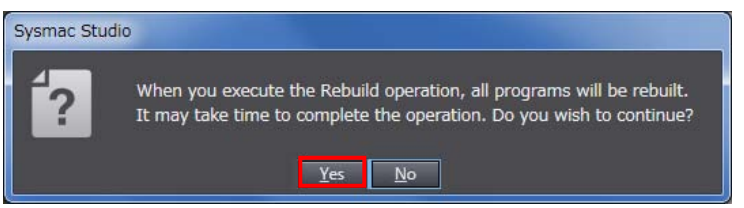

1	Select <b>Check All Programs</b> from the Project Menu.	
2	The Build Tab Page is displayed. Confirm that "0 Errors" and "0 Warnings" are displayed.	
3	Select <b>Rebuild Controller</b> from the Project Menu.	
4	A confirmation dialog box on the right is displayed. Confirm that there is no problem and click the <b>Yes</b> Button.	

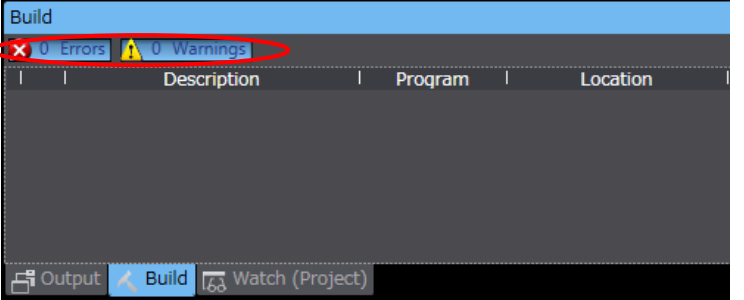
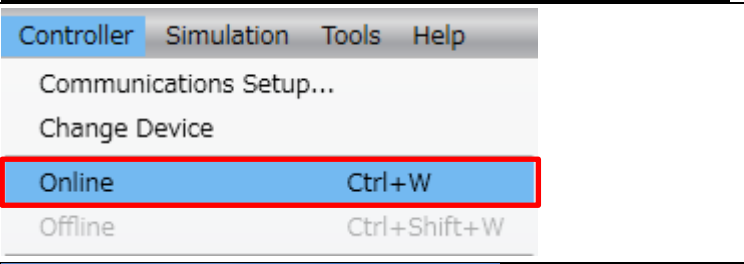
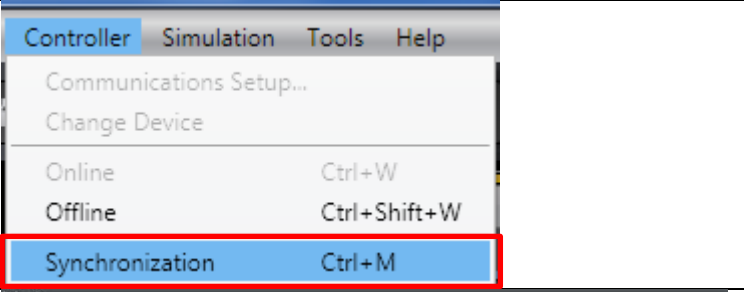
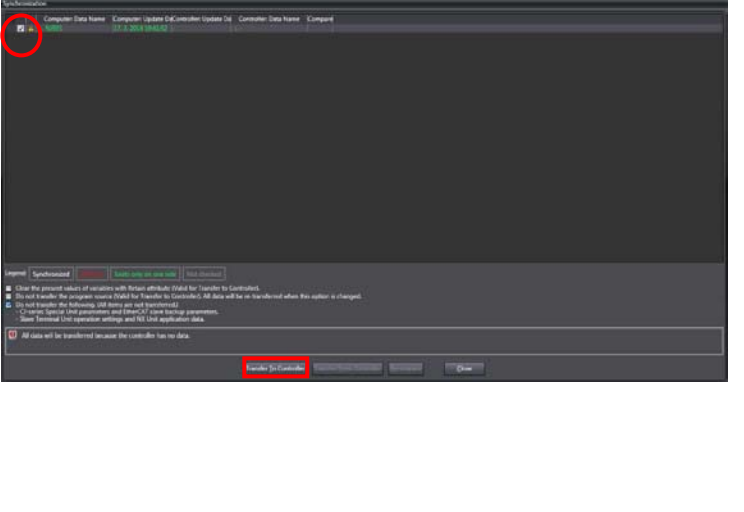

<p>5</p>	<p>Confirm that "0 Errors" and "0 Warnings" are displayed in the Build Tab Page.</p>	
<p>6</p>	<p>Select <b>Online</b> from the Controller Menu.</p>	
<p>7</p>	<p>Select <b>Synchronization</b> from the Controller Menu.</p>	
<p>8</p>	<p>The Synchronization Dialog Box is displayed. Confirm that the data to transfer (NJ501 in the right dialog box) is selected. Then, click the <b>Transfer To Controller</b> Button.</p> <p>*After executing the Transfer To Controller, the Sysmac Studio data is transferred to the Controller and the data is compared.</p>	



- 9 A confirmation dialog box on the right is displayed. Confirm that there is no problem and click the **Yes** Button.

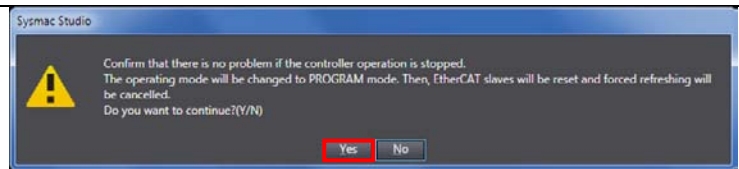

A screen stating "Synchronizing" is displayed.

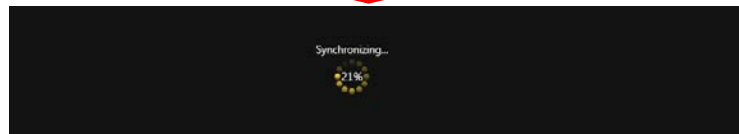

A confirmation dialog box on the right is displayed. Confirm that there is no problem and click the **No** Button.

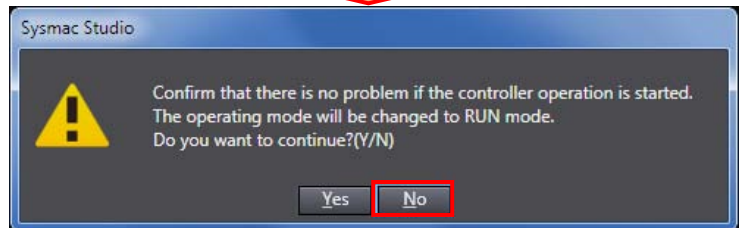

\*Do not return to RUN mode.

- 10 Confirm that the synchronized data is displayed with the color specified by "Synchronized" and that a message is displayed stating "The synchronization process successfully finished". If there is no problem, click the **Close** Button.

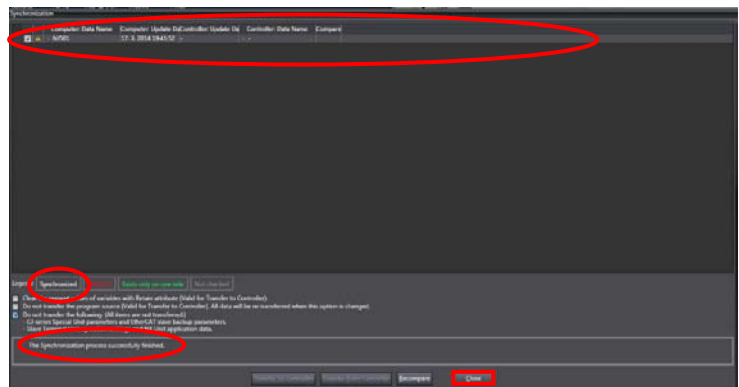

\*A message stating "The synchronization process successfully finished" is displayed if the Sysmac Studio project data and the data in the Controller match each other.

\*If the synchronization fails, check the wiring and repeat from step 1.

## 7.4. Setting the Vision Sensor Parameters

Set the parameters for the Vision Sensor.

### 7.4.1. Parameter Settings

Set the Vision Sensor parameters from the Sysmac Studio.



#### Precautions for Correct Use

Use the Sysmac Studio on the Personal computer to set up or adjust the Vision Sensor via Ethernet. You cannot set up or adjust the Vision Sensor through the Controller via EtherCAT.

- 1 Right-click **Node1: FQ-MS12x-M-ECT-v1.4 (E001):Offline** under **Configurations and Setup - EtherCAT** in the Multiview Explorer and select **Change version** from the menu.

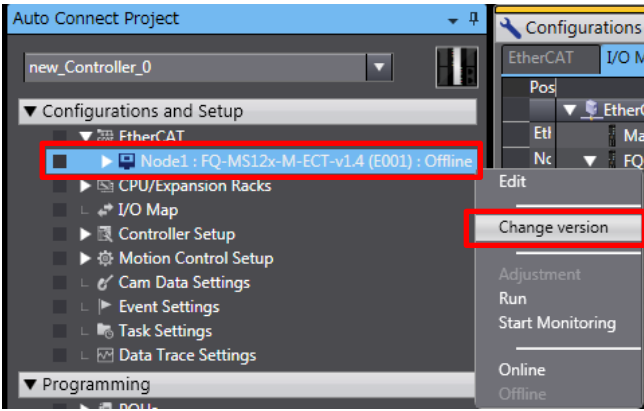

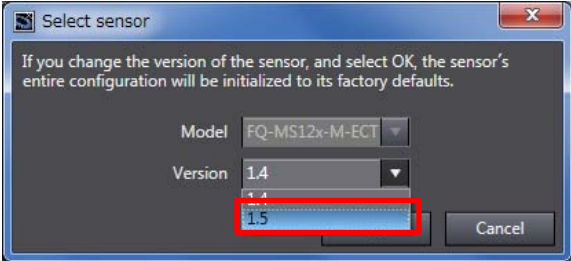
- 2 The Select sensor Dialog Box is displayed. Select **1.5** (Vision Sensor ver.) from the pull-down list.

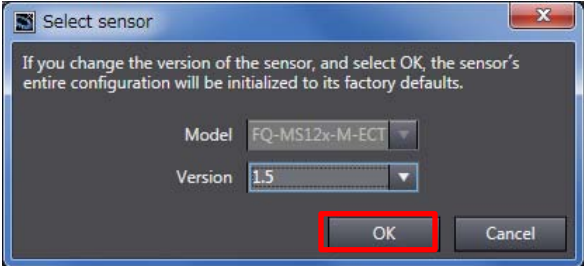

↓

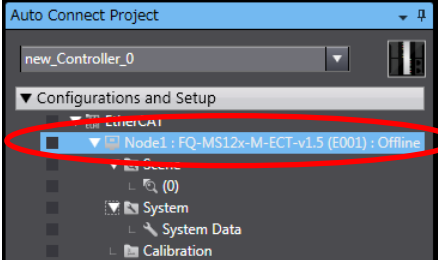

Click the **OK** Button to close the dialog box.
- 3 **Node1:FQ-MS12x-M-ECT-v1.5 (E001): Offline** is displayed.

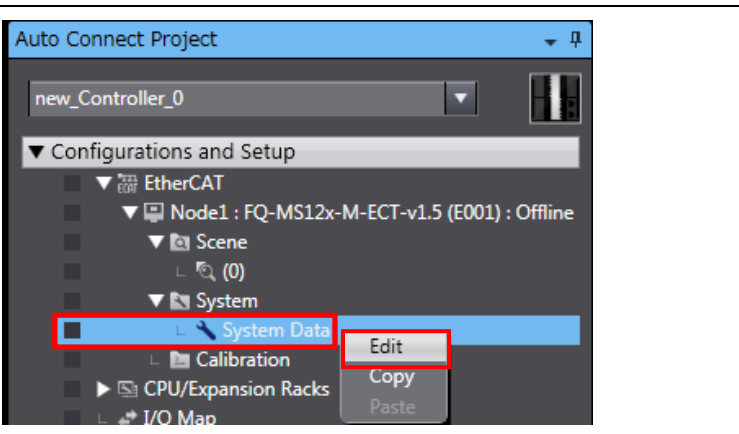
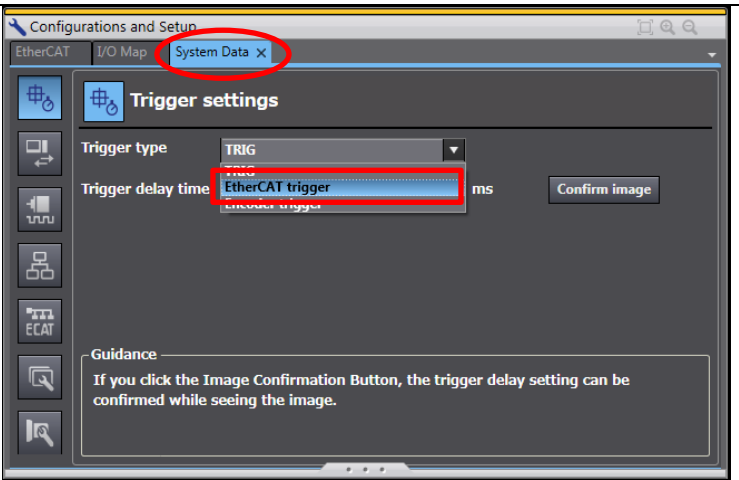
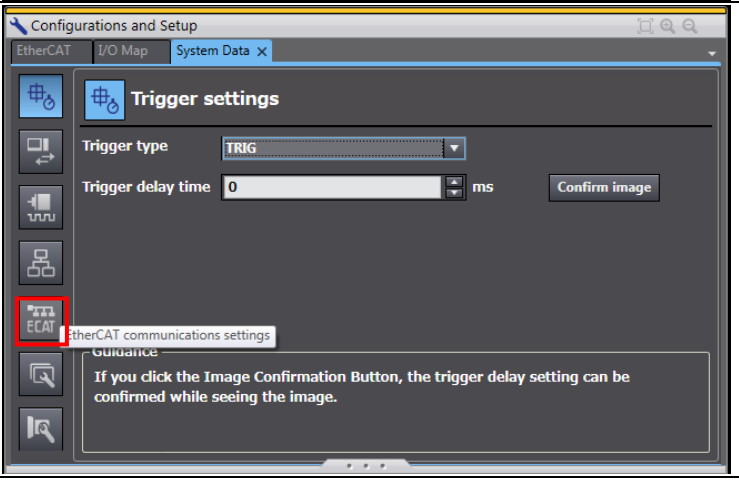
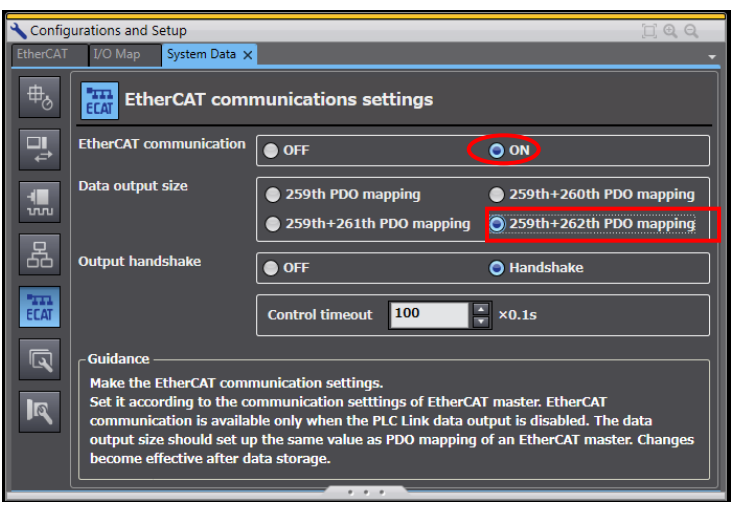

<p>4 Right-click <b>System Data</b> under <b>Configurations and Setup - EtherCAT - Node1:FQ-MS12x-M-ECT-v1.5 (E001):Offline - System</b> in the Multiview Explorer and select <b>Edit</b> from the menu.</p>	
<p>5 The System Data Tab Page is displayed in the Edit Pane. The Trigger settings Dialog Box is displayed. Select <b>EtherCAT trigger</b> from the Trigger type pull-down list.</p>	
<p>6 Click the <b>EtherCAT communications settings</b> Icon on the left to the System Data Tab Page.</p>	
<p>7 The EtherCAT communications settings Display is displayed in the System Data Tab Page. Confirm that EtherCAT communication is ON. Select <b>259th+262th PDO mapping</b> of Data output size.</p>	

8 Right-click **Node1:FQ-MS12x-M-ECT-v1.5 (E001):Offline** under **Configurations and Setup - EtherCAT** in the Multiview Explorer and select **Edit** from the menu.

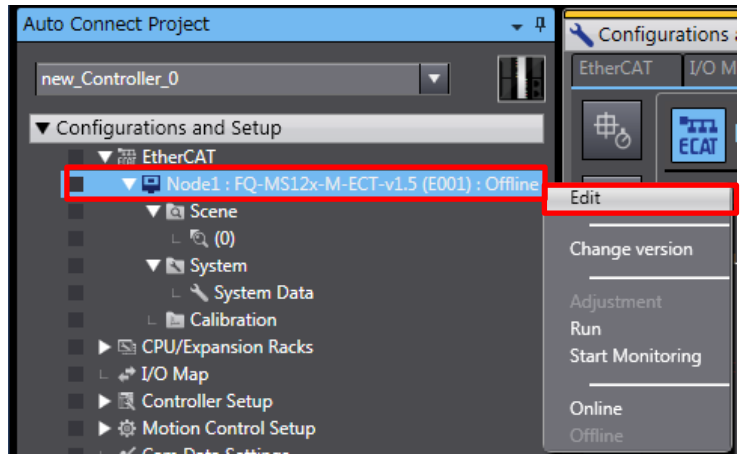

9 The Node1:FQ-MS12x-M-ECT-v1.5 Tab Page is displayed in the Edit Pane. Click the **Online** icon on the left to the Node1:FQ-MS12x-M-ECT-v1.5 Tab Page.

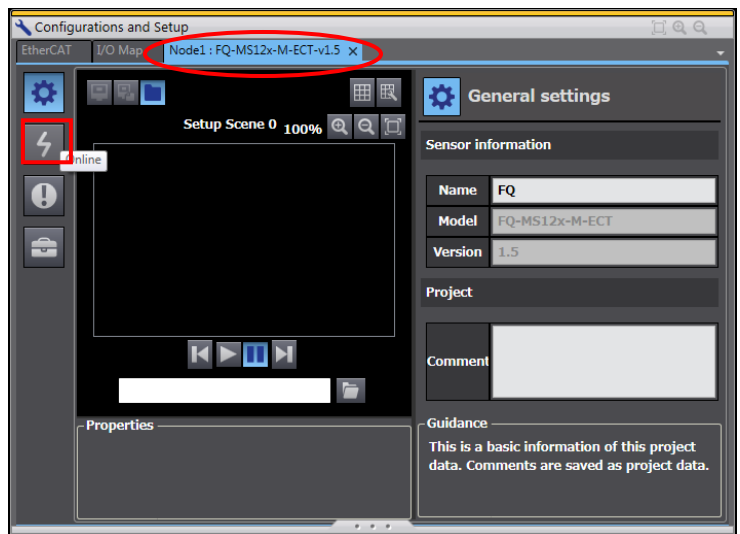

10 The Online Display is displayed. Click the **Connect** Button of **Sensor connection**.

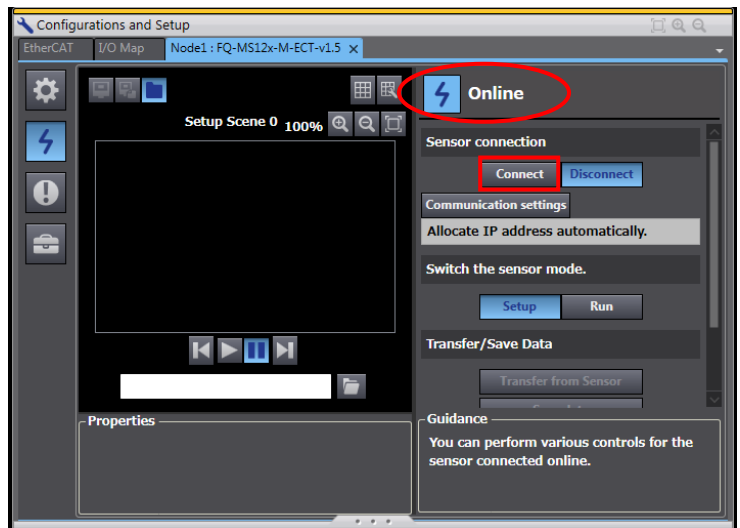

11 The Connection destination Dialog Box is displayed. Confirm that FQ-MS120-M-ECT and 1.5 (model and ver. of Vision Sensor) are displayed. Click the **Connect** Button.

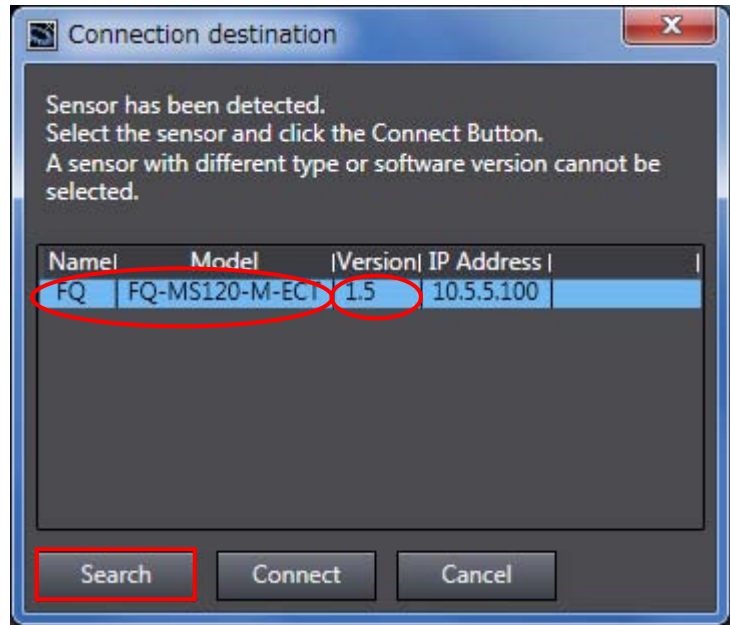

\*If the Smart Motion Tool Dialog Box is displayed, check the model (version) of "Project" and "Connection destination" for the Vision Sensor. Click the **OK** Button. Set the model (version) of connection destination of the Vision Sensor to the project by following steps 1 and 2.

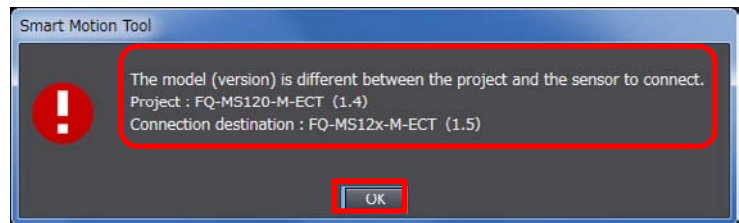

\*After the change is made to the model (version) of the Vision Sensor, the latest Vision Sensor's parameter before the change is initialized. Repeat steps 3 to 10.

12 When an online connection is established, the Node1:FQ-MS12x-M-ECT-v1.5 Tab Page is enclosed in yellow.

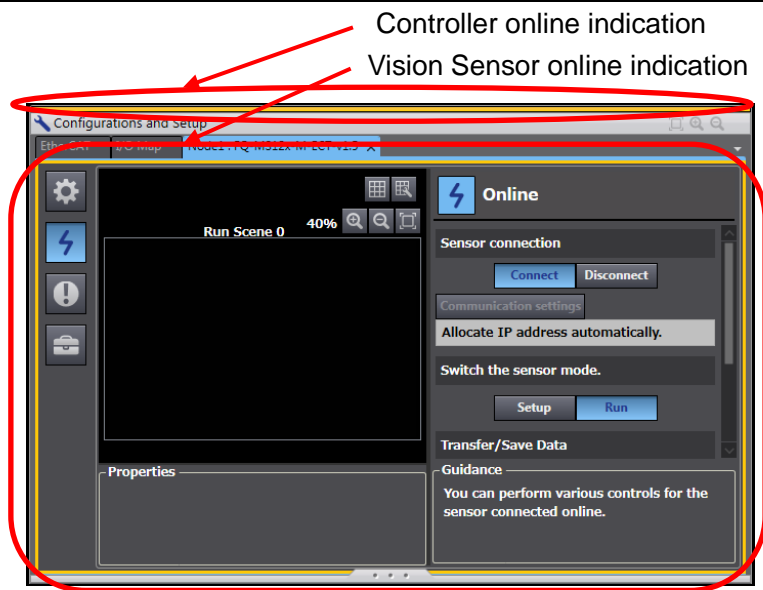

- 13 Click the **Setup** Button of Switch the sensor mode.

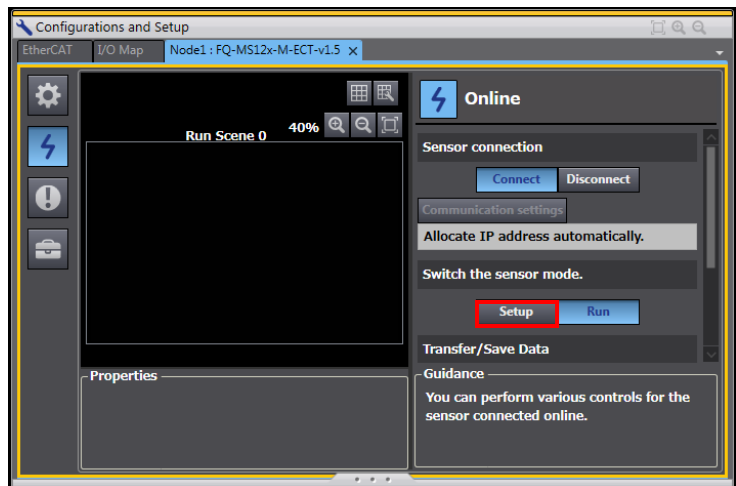

- 14 The Confirm change to Setup mode Dialog Box is displayed. Click the **Transfer to Sensor** Button.

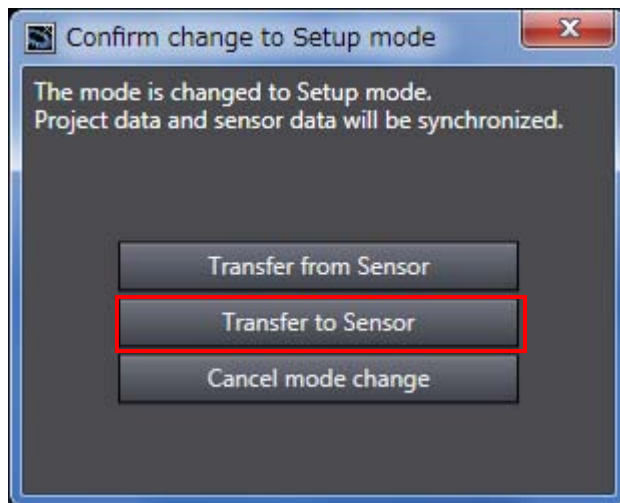

- 15 Confirm that Switch the sensor mode changes to Setup. Click the **Save data** Button of **Transfer/Save Data**.

\*If Transfer/Save Data is not displayed, scroll the pane by using the scroll bar until it appears.

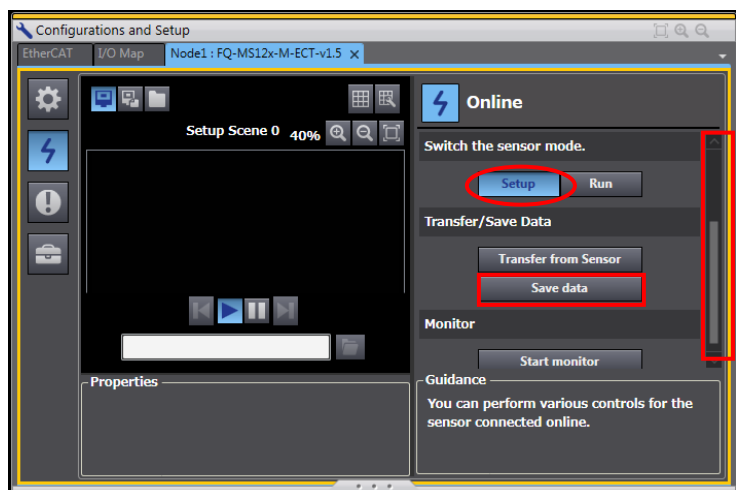

- 16 The Save data Dialog Box is displayed. Confirm that there is no problem and click the **Yes** Button.

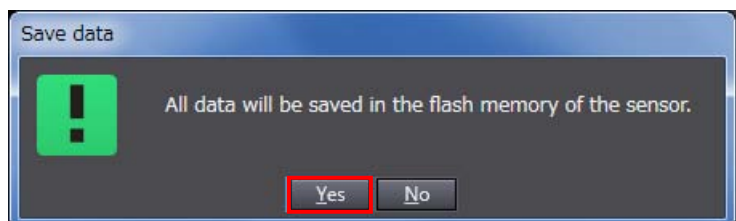

17 Click the **Tool** Icon on the left to the Node1:FQ-MS12x-M-ECT-v1.5 Tab Page.

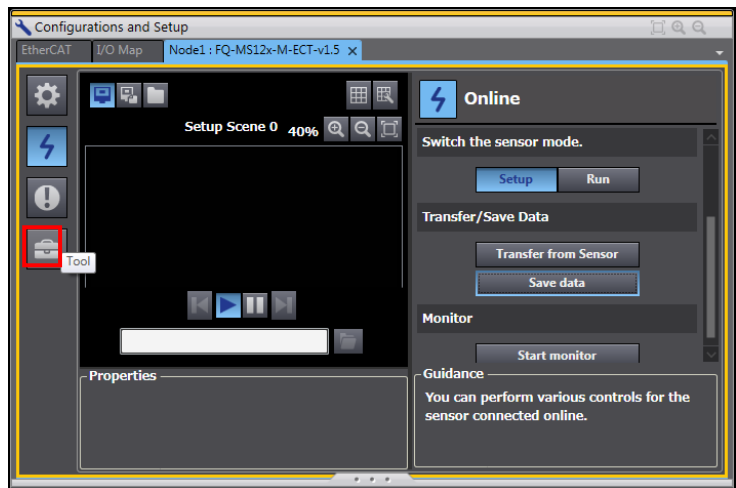

18 The Tool Display is displayed. Click the **Restart** Button of Sensor setup.

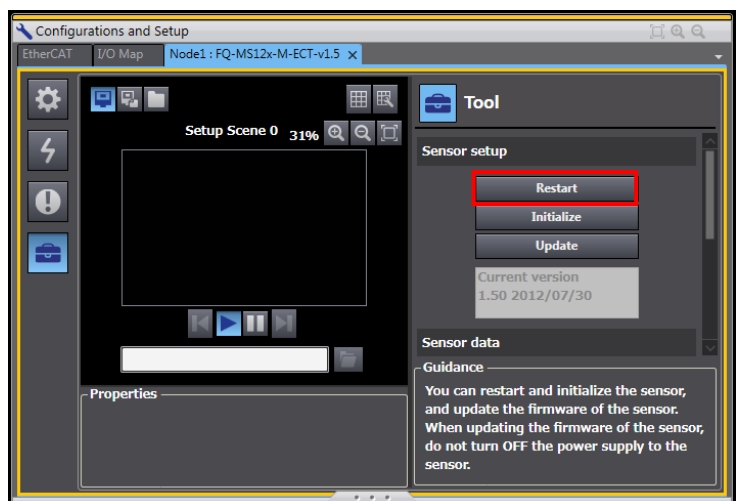

19 The Restart Dialog Box is displayed. Confirm that there is no problem and click the **Yes** Button.  
  
\*After restarting the Vision Sensor, the EtherCAT setting is enabled.

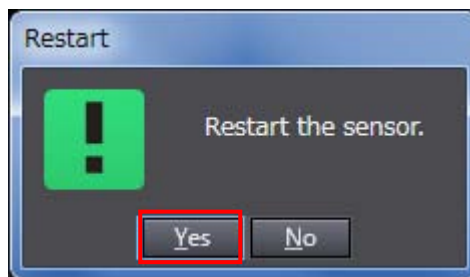

20 After restarting, the Vision Sensor goes offline, which causes Link OFF Error in the Controller.

21 Reset the error in the Controller. Click the **Troubleshooting** Button on the Sysmac Studio toolbar.





22 A message indicating "A Link OFF state occurred" is displayed in the Troubleshooting Window. Click the **Reset All** Button.

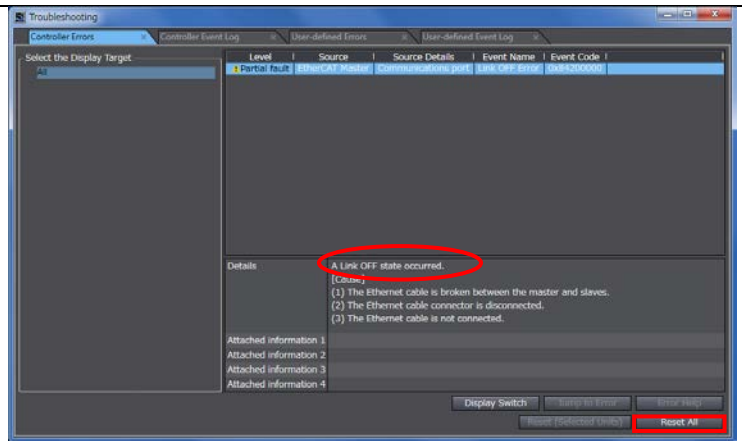

The Troubleshooting Dialog Box is displayed. Check the contents and click the **Yes** Button.

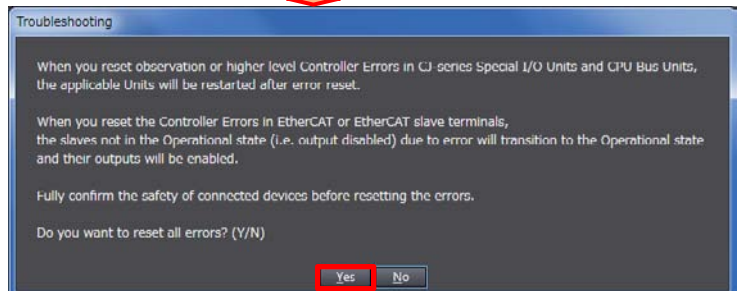

23 A message indicating "No Error" is displayed in the *Details* Field in the Troubleshooting Window.

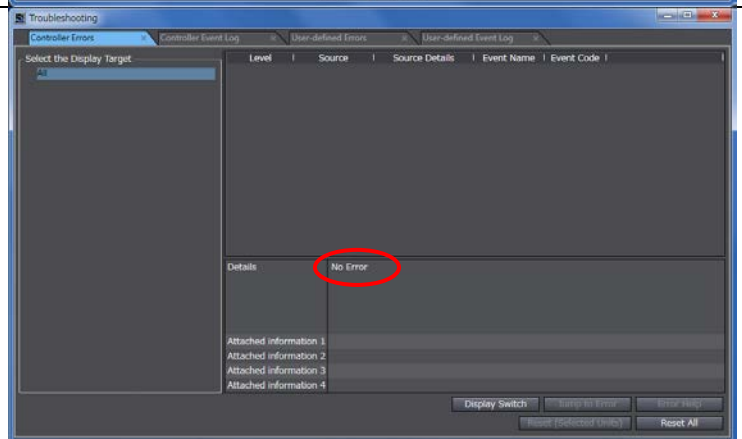

24 Go online with the Vision Sensor by following steps 9 to 12.

Confirm that Switch the sensor mode is RUN.

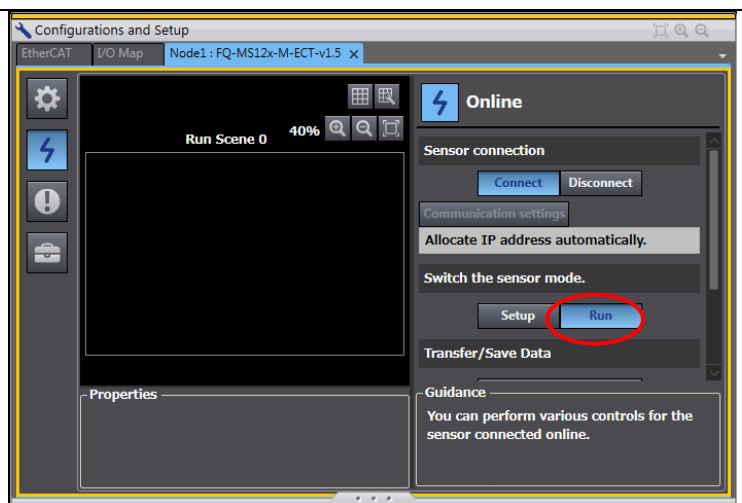



## 7.5. Checking the EtherCAT Communications

Confirm that the PDO Communications of EtherCAT are performed normally.

### 7.5.1. Checking the Connection Status

Check the connection status.

- 1 Confirm that the EtherCAT communications are performed normally by checking the LED indicators on the Controller.

The LED indicators in normal status are as follows:

[NET RUN]: Lit green

[NET ERR]: Not lit

[LINK/ACT]: Flashing yellow

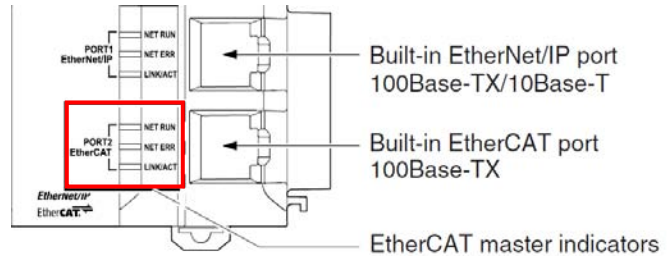

- 2 Check the LED indicators on the Vision Sensor.

The LED indicators in normal status are as follows:

[L/A IN]: Flashing green

[ECAT RUN]: Lit green

[ECAT ERR]: Not lit



### 7.5.2. Checking the Data that are Sent and Received

Confirm that the correct data are sent and received.

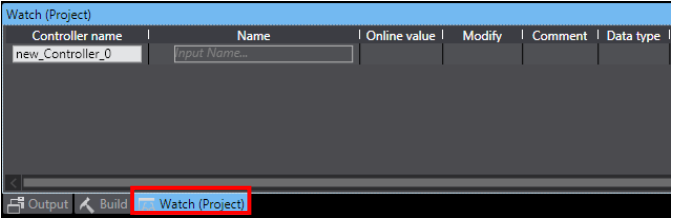
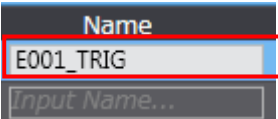
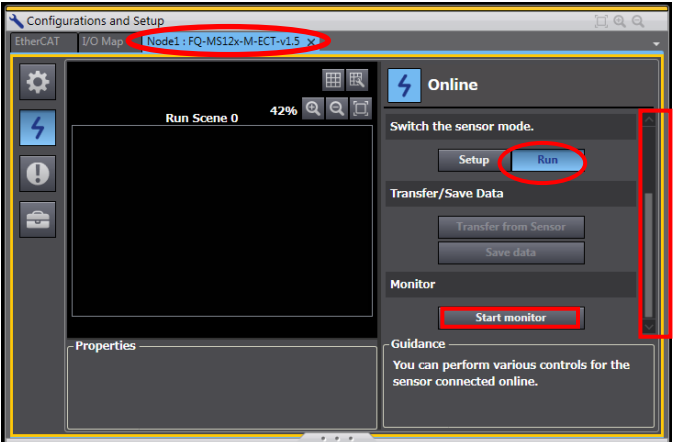
1	<p>Select the <b>Watch (Project)</b> Tab Page.</p>	
2	<p>Enter the following names in the Watch (Project) Tab Page for monitoring. Click an <i>Input Name...</i> in the <i>Name</i> Column to enter a new name. <i>E001_TRIG</i></p>	
3	<p>Start monitoring for the Vision Sensor on the Sysmac Studio. Display the Node1:FQ-MS12x-M-ECT-v1.5 Tab Page in the Edit Pane. Confirm that the Vision Sensor is connected, and Switch the sensor mode is Run. Click the <b>Start monitor</b> Button of <b>Monitor</b>.</p> <p>*When any of the following applies, perform 7.4. <i>Setting the Vision Sensor Parameters</i>.</p> <ul style="list-style-type: none"> <li>• The Node1:FQ-MS12x-M-ECT-v1.5 Tab Page is not displayed.</li> <li>• Online connection is not established with the Vision Sensor.</li> <li>• Switch the sensor mode is other than RUN.</li> </ul> <p>*If Monitor is not displayed, scroll the pane by using the scroll bar until it appears.</p>	

- 4 The Monitoring Window for the Vision Sensor is displayed. In the right example, Count is 0.

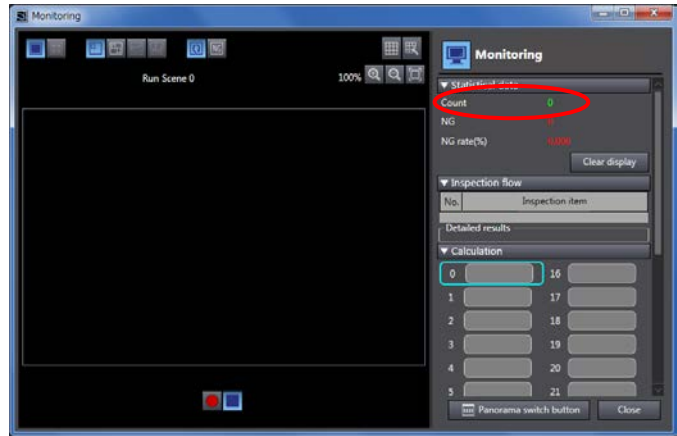

- 5 Confirm that the Online value of E001\_TRIG is False and click **TRUE** in the *Modify* Column in the Watch (Project) Tab Page.

Name	Online value	Modify	Comment	Data type
E001_TRIG	False	TRUE FALSE		BOOL



Name	Online value	Modify	Comment	Data type
E001_TRIG	True	TRUE FALSE		BOOL

Confirm that the Online value changes to True.

- 6 Confirm that overall judgement is "OK", Count changes to 1, and an image measured by the Vision Sensor is displayed in the Monitoring Window.

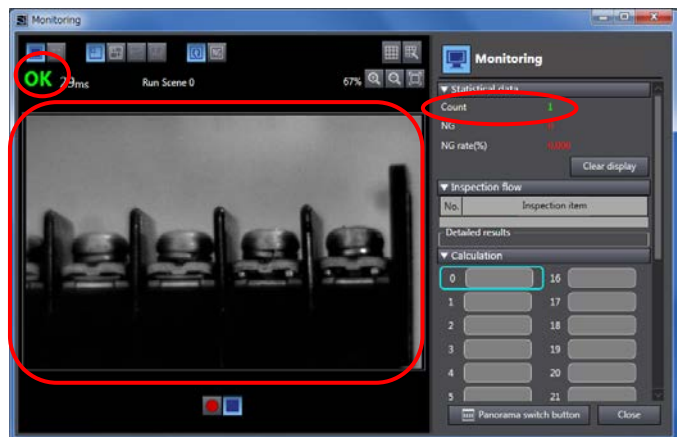

## 8. Initialization Method

This document explains the setting procedure from the factory default setting. Some settings may not be applicable as described in this document unless you use the devices with the factory default setting.

### 8.1. Initializing the Controller

To initialize the settings of the Controller, select **Clear All Memory** from the Controller Menu of the Sysmac Studio. The Clear All Memory Dialog Box is displayed. Check the contents and click the **OK** Button.

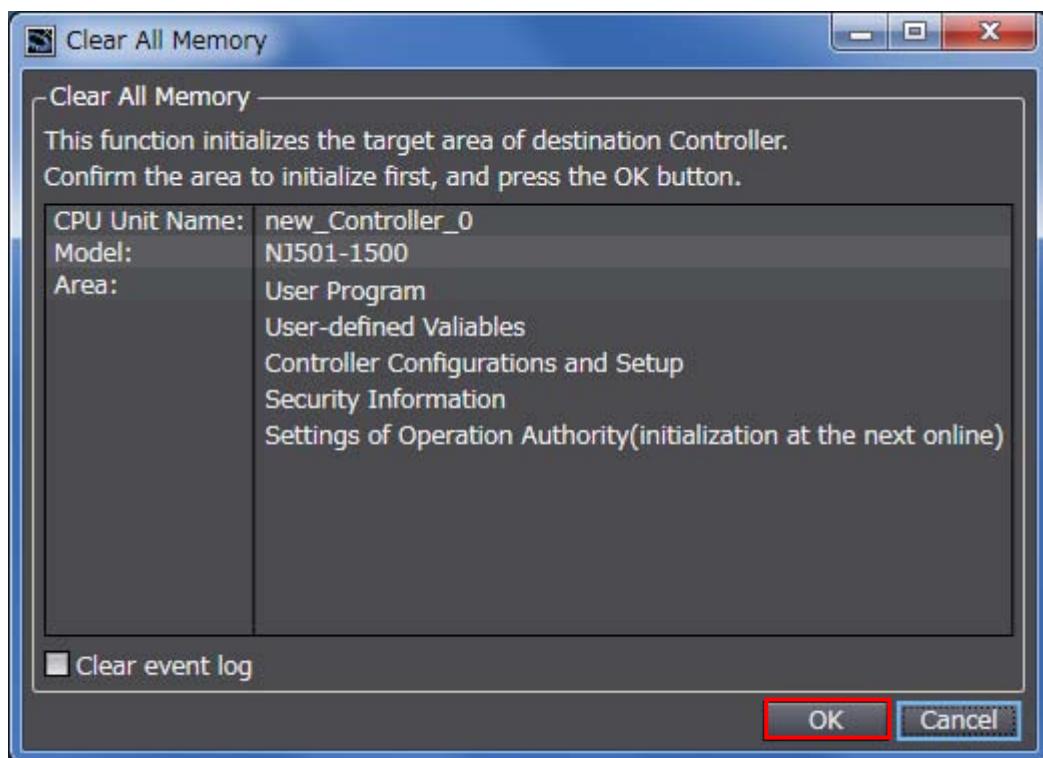

### 8.2. Initializing the Vision Sensor

For how to initialize the Vision Sensor, refer to *Initializing the Sensor* in *7-7 Functions Related to the Sensor System Environment of the Vision Sensor FQ-M-series Specialized Vision Sensor for Positioning User's Manual* (Cat.No.Z314).

## 9. Revision History

Revision code	Date of revision	Revision reason and revision page
01	Jul. 7, 2014	First edition

**OMRON Corporation Industrial Automation Company**

Tokyo, JAPAN

Contact: [www.ia.omron.com](http://www.ia.omron.com)

**Regional Headquarters**

**OMRON EUROPE B.V.**

Wegalaan 67-69-2132 JD Hoofddorp  
The Netherlands

Tel: (31)2356-81-300/Fax: (31)2356-81-388

**OMRON ELECTRONICS LLC**

One Commerce Drive Schaumburg,  
IL 60173-5302 U.S.A.

Tel: (1) 847-843-7900/Fax: (1) 847-843-7787

**OMRON ASIA PACIFIC PTE. LTD.**

No. 438A Alexandra Road # 05-05/08 (Lobby 2),  
Alexandra Technopark,  
Singapore 119967

Tel: (65) 6835-3011/Fax: (65) 6835-2711

**OMRON (CHINA) CO., LTD.**

Room 2211, Bank of China Tower,  
200 Yin Cheng Zhong Road,  
PuDong New Area, Shanghai, 200120, China

Tel: (86) 21-5037-2222/Fax: (86) 21-5037-2200

**Authorized Distributor:**

© OMRON Corporation 2014 All Rights Reserved.  
In the interest of product improvement,  
specifications are subject to change without notice.

**Cat. No. P610-E1-01**

0714(-)